



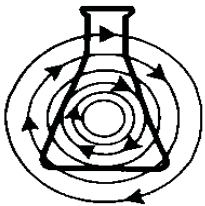
Guide to Operations

C-25 Classic Incubator & C-25KC Classic CFC-Free Refrigerated Incubator Shakers

MANUAL NO: M1246-0051

Revision H

October 29, 2004



NEW BRUNSWICK SCIENTIFIC CO., INC.

BOX 4005 • 44 TALMADGE ROAD • EDISON, NJ 08818-4005

Telephone: 1-732-287-1200 • 1-800-631-5417

Fax: 732-287-4222 • Telex: 4753012 NBSCO

Internet: <http://www.nbsc.com> • E-mail: bioinfo@nbsc.com

INTERNATIONAL OFFICES:

BELGIUM

New Brunswick Scientific NV-SA
Stationsstraat 180/4
3110 Rotselaar
België/Belgique
Tel: 32 (0)16 56 28 31
Fax: 32 (0)16 57 27 53
E-mail: sales@nbsnv-sa.be

CHINA

New Brunswick Scientific Co., Inc.
Room 1501, Xiangjiang Building, No. 18
Lane 1265, Zhongshan Road (W)
Shanghai 200051, P.R. China
Tel: 86 21 3223 0203
Fax: 86 21 6278 7182
E-mail: nbschc@online.sh.cn

FRANCE

New Brunswick Scientific SARL
3, rue des Deux-Boules
75001 Paris
France
Tel: 33 (0)1 4026 2246
Fax: 33 (0)1 4026 5423
E-mail: sales@nbssarl.fr

GERMANY

New Brunswick Scientific GmbH
In Der Au 14
D-72622 Nürtingen
Deutschland
Tel: 49 (0)7022 932490
Fax: 49 (0)7022 32486
E-mail: sales@nbsgmbh.de

THE NETHERLANDS

New Brunswick Scientific BV
Kerkenbos 1101, 6546 BC Nijmegen
P.O Box 6826, 6503 GH Nijmegen
Nederland
Tel: 31 (0)24 3717 600
Fax: 31 (0)24 3717 640
E-mail: sales@nbsbv.nl

UNITED KINGDOM

New Brunswick Scientific (UK) Ltd.
17 Alban Park
St. Albans, Herts. AL4 0JJ
United Kingdom
Tel: 44 (0)1727 853855 or 0800 581331
Fax: 44 (0)1727 835666
E-mail: bioinfo@nbsuk.co.uk
Web: www.nbsuk.co.uk

THIS PAGE IS INTENTIONALLY BLANK

**WARNING!**

This equipment *must* be operated as described in this manual. If operational guidelines are not followed, equipment damage and personal injury *can* occur. Please read entire User's Guide before attempting to use this unit.

THIS PAGE IS INTENTIONALLY BLANK

Copyright Notice

New Brunswick Scientific Company, Inc.
Box 4005 44 Talmadge Road
Edison, New Jersey 08818-4005

© Copyright 2004 New Brunswick Scientific Co., Inc.

All Rights Reserved.

Reproduction, adaptation, or translation without prior written permission from New Brunswick Scientific is prohibited.

Disclaimer Notice

New Brunswick Scientific Co., Inc. reserves the right to change information in this document without notice. Updates to information in this document reflect our commitment to continuing product development and improvement.

Manual Conventions



Notes contain important and useful information separate from text.



***Caution* messages appear before procedures which, if not observed, could result in damage to the equipment.**



***Warning* messages alert you to specific procedures or practices which, if not followed correctly, could result in serious personal injury.**

Bold

Text in bold face type emphasizes key words or phrases.

THIS PAGE IS INTENTIONALLY BLANK



THIS PAGE IS INTENTIONALLY BLANK

TABLE OF CONTENTS

1	OVERVIEW	13
1.1	C-25 SPECIFICATIONS	14
1.2	C-25KC SPECIFICATIONS	15
2	INSPECTION, VERIFICATION & UNPACKING OF EQUIPMENT.....	17
2.1	INSPECTION OF BOXES	17
2.2	UNPACKING	17
2.3	INSPECTION OF EQUIPMENT	17
3	PREPARING THE LOCATION.....	19
3.1	PHYSICAL LOCATION	19
3.2	ENVIRONMENT	19
4	FEATURES	21
4.1	KEYPAD	21
4.2	PLATFORM ASSEMBLIES	22
5	GETTING STARTED	23
5.1	INSTALLATION OF PLATFORM	23
5.2	INSTALLING FLASK CLAMPS	24
5.3	ELECTRICAL CONNECTIONS	25
6	OPERATION	27
6.1	STARTING THE SHAKER.....	27
6.2	CONTINUOUS (UNLIMITED) RUN.....	28
6.3	CHECKING A SETPOINT	28
6.4	TIMED FUNCTIONS	28
6.5	ALARM FUNCTIONS.....	29
6.6	TEMPERATURE SETPOINT.....	29
6.7	TOTAL RUNNING TIME.....	30
6.8	MAINT INDICATOR.....	30
6.9	POWER FAILURE	30
7	PREVENTIVE MAINTENANCE.....	31
7.1	CLEANING EXTERNAL SURFACES.....	31
7.2	FUSE REPLACEMENT	31
7.3	BELT REPLACEMENT	32
8	TROUBLESHOOTING	35
9	REPLACEMENT PARTS & ACCESSORIES.....	37
9.1	REPLACEMENT PARTS.....	37
9.2	ACCESSORIES.....	37

10 DRAWINGS39
10.1 LIST OF DRAWINGS61
10.2 LIST OF TABLES61
11 INDEX.....63

1 OVERVIEW

The C-25 Classic Incubator and C-25KC Classic Refrigerated Incubator Shakers are large capacity shakers utilizing an eccentric counter balanced drive to provide horizontal plane rotary motion in a 1" (2.54 cm) circular orbit. A Proportional/Integral (PI) Microprocessor controller with instantaneous digital feedback controls the speed over a range of 50-400 rpm.

The C-25 provides temperature control over a range of 7°C above ambient to 60°C, and the C-25KC provides temperature control over a range of 15°C below ambient (minimum 4°C) to 60°C. Ambient temperature is defined as the temperature within one meter of the shaker.

The shakers may be operated either continuously or in a timed mode via a programmable timer for shaking periods of 0.1 hr. to 99.9 hrs.

For safe operation, both the C-25 and C-25KC are designed with a safety switch that automatically stops the shaker mechanism when the lid is lifted.

In addition, the C-25 and C-25KC are equipped with visual and audible alarms that alert the user to the following conditions:

- The end of a timed run
- Deviations of shaking speed
- Deviations of temperature setpoint
- Power failure
- Lid open

A wide variety of platforms can be used with the C-25 or C-25KC. Dedicated platforms are available for a variety of flask sizes. Universal platforms, utility trays, utility carriers and test tube racks are also available.

1.1 C-25 Specifications

C-25 Classic Incubator Shaker	
Speed:	40-400 rpm
Control Accuracy	± 2 rpm
Indication	3 Digit LED, in 1 rpm increments
Stroke	1" (2.54 cm)
Temperature:	7°C above ambient temperature* to 60°C
Control Accuracy	± 0.25°C
Indication	3 Digit LED, in 0.1°C increments
Ambient* Operating Environment	5 - 35°C, 20 to 90% relative humidity, non-condensing
Alarms	Visible and audible warning indication when speed deviates more than 5 rpm, and temperature more than 1°C from setpoints, and when timer has expired.
Timer	0.1 hr to 99.9 hrs. Shuts off agitation at end of period. Can be deactivated for continuous operation.
Automatic Restart	Automatic restart after power is restored. Setpoints and operating status are retained in memory during power interruption.
Drive Interrupt	Automatic drive-interrupt when cover is opened.
Electrical Requirements	110/120V AC 50/60 Hz, 1320 VA 220/240V AC 50/60 Hz, 1320 VA
Platform	30" X 18" (76 X 46 cm), Stainless Steel
Overall Dimensions	44.3" W X 29" D X 33.4" H (113 X 74 X 85 cm)
Chamber Dimensions	23.5" W X 22" D X 19" clearance above platform (88 X 56 X 48 cm)
Weight	420 lbs (191 kg) Net, 450 lbs (204 kg) Gross

*Ambient temperature is defined as the temperature within one meter of the shaker.

1.2 C-25KC Specifications

C-25KC Classic Refrigerated Incubator Shaker	
Speed:	40-400 rpm
Control Accuracy	± 2 rpm
Indication	3 Digit LED, in 1 rpm increments
Stroke	1" (2.54 cm)
Temperature:	15°C below ambient temperature* (min. 4°C) to 60°C
Control Accuracy	± 0.25°C
Indication	3 Digit LED, in 0.1°C increments
Ambient* Operating Environment	5 - 35°C, 20 to 90% relative humidity, non-condensing
Alarms	Visible and audible warning indication when speed deviates more than 5 rpm, and temperature more than 1°C from setpoints, and when timer has expired.
Timer	0.1 hr to 99.9 hrs. Shuts off agitation at end of period. Can be deactivated for continuous operation.
Automatic Restart	Automatic restart after power is restored. Setpoints and operating status are retained in memory during power interruption.
Drive Interrupt	Automatic drive-interrupt when cover is opened.
Refrigerant	R-134A
Electrical Requirements	110/120V AC 50/60 Hz, 1980 VA 220/240V AC 50/60 Hz, 1980 VA
Platform	30" X 18" (76 X 46 cm), Stainless Steel
Overall Dimensions	44.3" W X 29" D X 33.4" H (113 X 74 X 85 cm)
Chamber Dimensions	23.5" W X 22" D X 19" clearance above platform (88 X 56 X 48 cm)
Weight	450 lbs (204 kg) Net, 480 lbs (218 kg) Gross

*Ambient temperature is defined as the temperature within one meter of the shaker.

THIS PAGE IS INTENTIONALLY BLANK

2 INSPECTION, VERIFICATION & UNPACKING OF EQUIPMENT

2.1 *Inspection of Boxes*

After you receive your order from New Brunswick Scientific, inspect the boxes carefully for any damage that may have occurred during shipping. Report any damage to the carrier and to your local NBS Sales Order Department.

2.2 *Unpacking*

Save all packing materials and User's Guide. If any part of your order was damaged during shipping, missing pieces, or fails to operate properly, please fill out the *Customer Satisfaction Form 6300* provided and return by fax.



WARNING!

Do not attempt to lift the C-25 or C-25KC by hand. Always use a lifter or suitable equipment when raising the unit.

There are two small plastic straps holding the bearing housing in place during shipping. Remove the straps from the bearing housing once the unit is unpacked and inspected.

2.3 *Inspection of Equipment*

Verify against your NBS packing list that you have received the correct materials. You should have received a Power Kit (power cord, fuse, hex wrench and key) with your shaker. Make sure your electrical supply matches the electrical specification of the power kit and the shaker (both of which should be the same).

THIS PAGE IS INTENTIONALLY BLANK

3 PREPARING THE LOCATION

3.1 Physical Location

It is essential that the instrument be situated in a area where there is sufficient space for the shaker and platform to clear walls and obstructions during operation. The surface on which the unit is placed must be smooth, level, and able to support the shaker under full load operating conditions.



WARNING!

Do not attempt to lift the C-25 or C-25KC by hand. Always use a lifter or suitable equipment when raising the unit.

The feet can be adjusted for necessary leveling. Loosen the locking nuts on the threaded studs attached to the feet of the shaker. Retighten when you have achieved the correct level for your shaker.

3.2 Environment

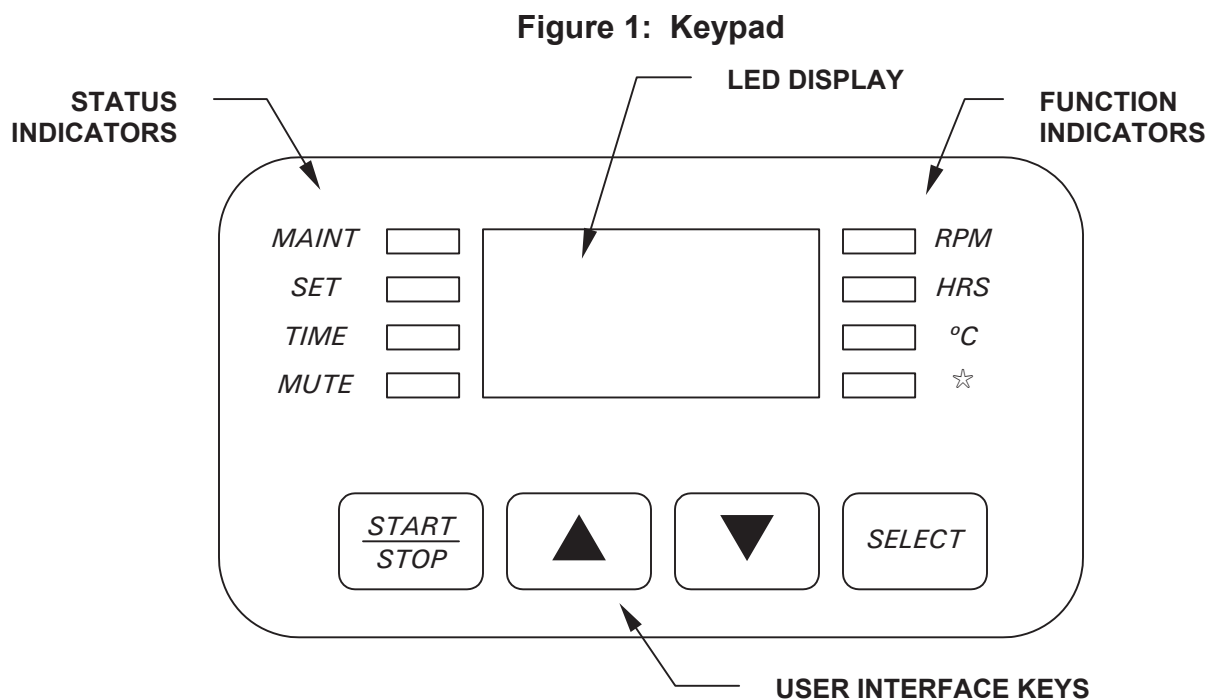
The shaker is designed to operate optimally in the following ambient conditions:

- 5 - 35°C
- 20 to 90% Relative Humidity non-condensing

THIS PAGE IS INTENTIONALLY BLANK

4 FEATURES

4.1 Keypad



LED DISPLAY

The digital display on the control panel is a three-digit **LED DISPLAY**. During normal shaker operation the display will indicate:

- Shaker status (on/off)
- Shaking speed
- Chamber temperature
- Setpoints
- Hours remaining (timed run)
- Lid open

USER INTERFACE KEYS

- **START/STOP** This key is used to start or stop the shaker. It will also activate or stop the timer when a timed run is desired.
- **SELECT** This key is used to change the displayed parameter.

- **▲(UP), ▼(DOWN)** These keys are used to adjust the setpoint of a displayed parameter up or down. They also allow the user to enter the **SET MODE** for setpoint changes.

STATUS INDICATORS

Four status indicator lights are located to the left of the **LED DISPLAY**. They are:

- **MAINT** Remains lit after 10,000 hours of use. Accumulated running time is internally monitored and may be displayed as a guideline.
- **SET** Indicates that the shaker is in the **SET MODE** and setpoints are being displayed and can be altered.
- **TIME** Indicates that the timer is in operation. The shaker can be programmed to run for a preset time from 0.1 hr. to 99.9 hrs. The timer can be disengaged without stopping an ongoing run.
- **MUTE** Indicates the status of the audible alarm. When illuminated, the audible alarm is disabled.

FUNCTION INDICATORS

Four function indicator lights are located to the right of the **LED DISPLAY**. They indicate the current parameter being displayed.

- **RPM** revolutions per minute
- **HOURS** time remaining
- **°C** interior chamber temperature
- ☆ not applicable

4.2 Platform Assemblies

The C-25 and C-25KC can be used with a wide variety of NBS 18 x 30 inch (46 x 76 cm) platforms, which will accept a variety of clamps for flasks test tubes, etc. **A platform is a separate item that is required for operation.** See Section 9, *Replacement Parts & Accessories*, for details.

5 GETTING STARTED

5.1 Installation of Platform

A platform must be installed on the unit prior to use.

The unit is shipped with the four Allen (hexagonal, countersunk) head platform screws installed in the subplatform of the bearing housing. These screws must be removed before installing a platform. The Allen (“hex”) wrench is provided.

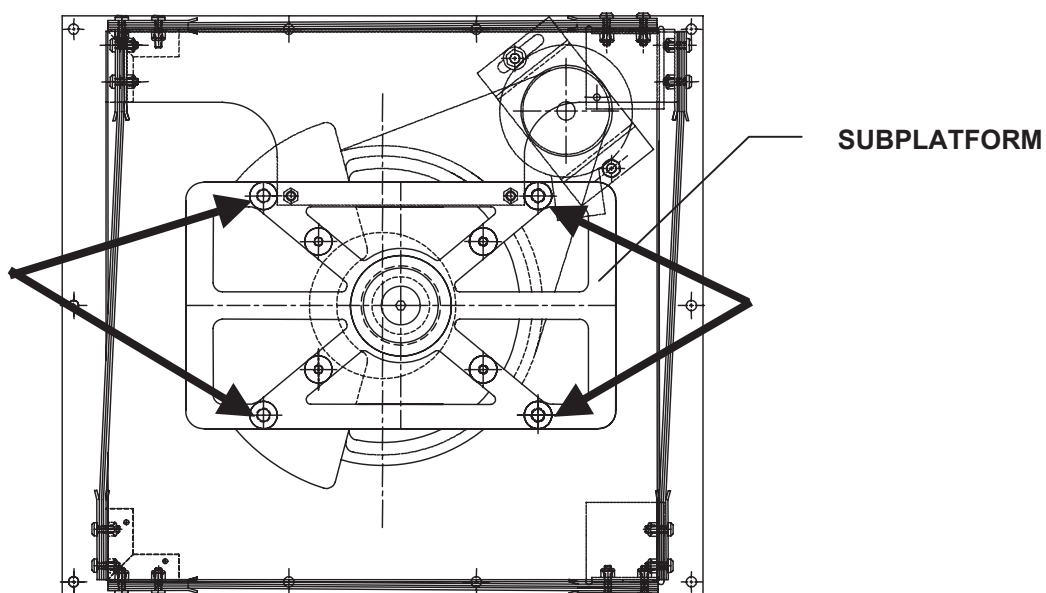


NOTE:

There are two small plastic straps holding the bearing housing in place during shipping. The straps must be removed from the unit

1. Using the 7/32-inch hex wrench provided, remove the four Allen head platform screws from the sub-platform.
2. Place the platform on the **SUBPLATFORM**. Align the mounting holes of the platform with the platform screw locations in the **SUBPLATFORM**.
3. Insert the four platform screws (Allen head) provided and tighten them with the 7/32-inch hex wrench provided to secure platform.

Figure 2: Platform Screw Locations



5.2 Installing Flask Clamps

Flask clamps purchased for use with universal platforms (see Section 9.2) require installation. Clamps are installed by securing the base of the clamp to the platform with the correct type and number of screws. All clamps are shipped complete with hardware.

Clamps for 2-, 2.8- and 4-liter flasks are shipped with an additional girdle to keep the flasks in place. The girdle is an assembly of springs and sections of rubber tubing. One girdle is already in place on the clamp, the other is packed separately. To install these double girdle clamps:

1. Place the clamp on the platform, aligning its mounting holes with holes on the platform. Secure the clamp in place using the flat Phillips head screws provided (#S2116-3051, 10-24 x 5/16-inch). Use Figure 3b to help you identify the proper screws, as three different types of screws are shipped with the clamps.
2. With the first girdle in place, as delivered, on the upper part of the clamp body (see Figure 3a), insert an empty flask into the clamp.
3. After making sure the sections of tubing are located between the clamp legs, roll the first girdle down the legs of the clamp as far as it can go. The tubing sections will rest against the platform, and the springs will be under the clamp base.
4. Place the second girdle around the upper portion of clamp body (just as the first girdle was initially). Make sure that its spring sections rest against the clamp legs, while its rubber tubing sections sit against the flask, in between the clamp legs.

Figure 3a: Double Girdle Clamp Installation

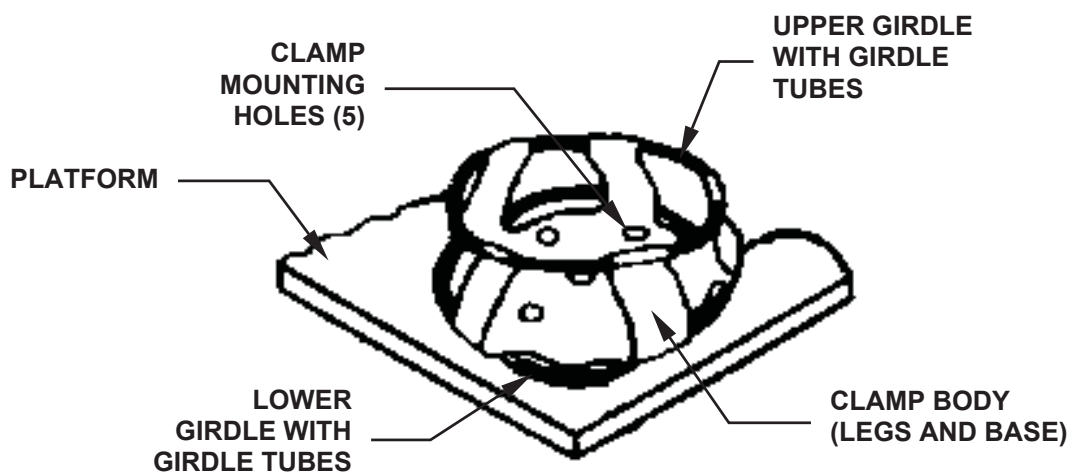


Figure 3b: Clamp Fastener




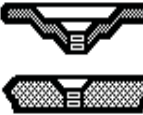
**NOTE:**

The upper girdle secures the flask within the clamp, and the bottom girdle keeps the flask from spinning.

NBS flask clamps are used on a variety of shaker platforms. Flat head screws of different lengths and thread pitch are used to secure the clamp, and all types are provided when you purchase clamps. To identify the proper screw for your shaker application by reference to the head style, consult Table 1 below, find the proper screws and set the others aside:

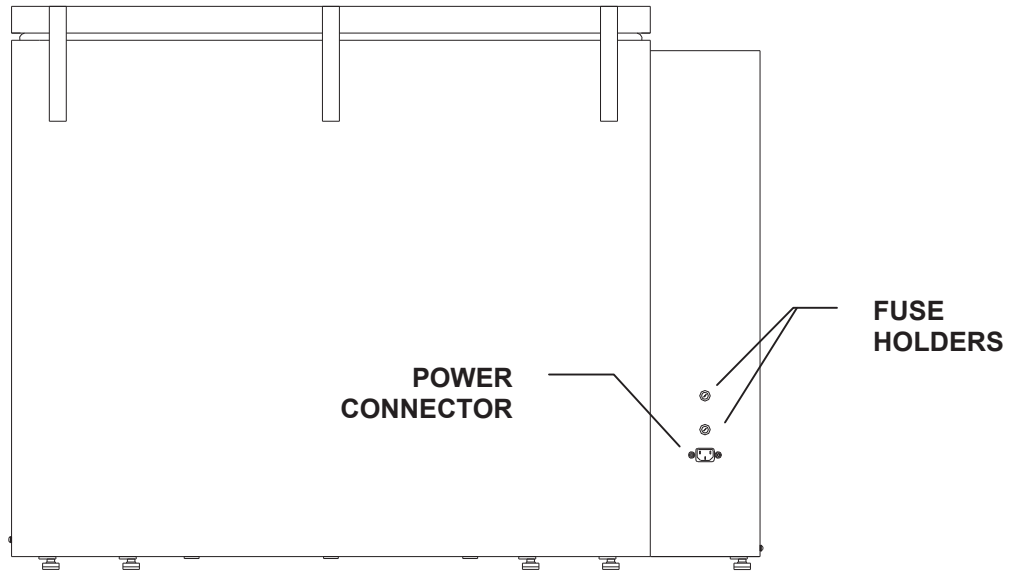
Table 1: Clamp Hardware Application Chart

No matter what size the clamp, use these screws to fasten them to your platform:

	<i>Description</i>	<i>Part Number</i>	<i>Qty.</i>	<i>Application</i>
	10-24 x 5/16 (7.9 mm) flat Phillips (+) head screw	S2116-3051	1	5/16" (7.9 mm) thick aluminum, phenolic and stainless steel platforms. 

5.3 Electrical Connections

Before making electrical connections, verify that the power source voltage matches the voltage on the **ELECTRICAL SPECIFICATION PLATE** and the **ON/OFF SWITCH** is on the **OFF** position. The **ELECTRICAL SPECIFICATION PLATE** is located on the side panel of the unit near the **ON/OFF SWITCH**. Connect the **POWER CORD** to the **POWER CONNECTOR** and the other end to a suitable, grounded receptacle.

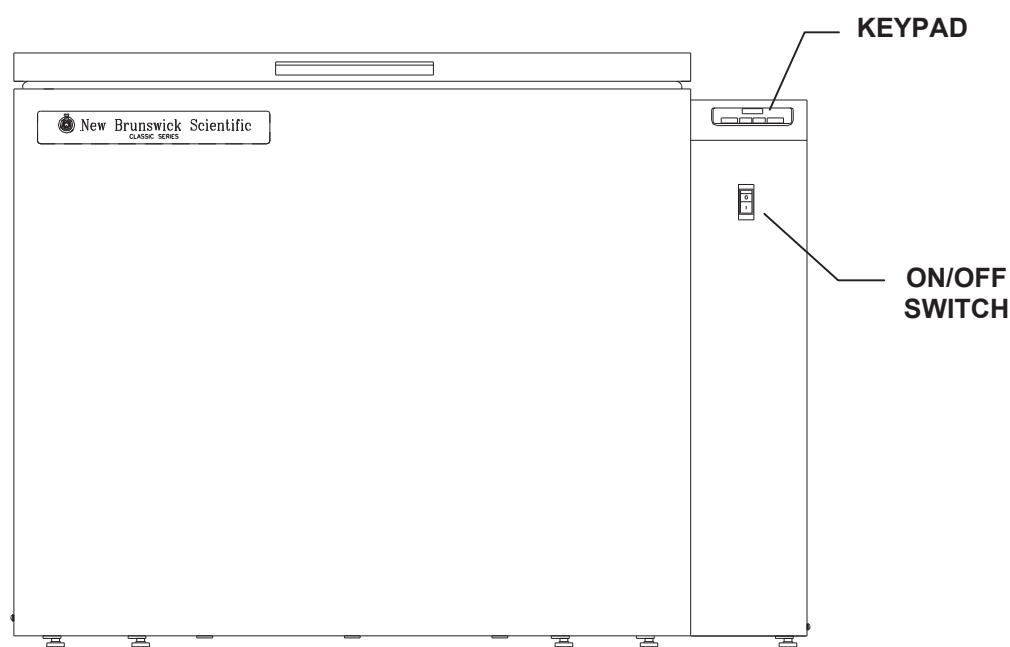
Figure 4: C-25 and C-25KC Rear Panel

6 OPERATION

6.1 Starting the Shaker

To initially start the shaker, close the lid and turn the **ON/OFF SWITCH** on the front panel of shaker to the **ON** position. If the shaker begins to operate, the **LED DISPLAY** will track the speed as it accelerates to the last entered setpoint. The shaking action may be stopped or started by pressing the **START/STOP KEY**.

Figure 5: C-25 and C-25KC Front Panel



NOTE:

The shaker will not operate if the lid is open. This is indicated by the word “lid” appearing in the LED DISPLAY.

6.2 Continuous (Unlimited) Run

1. Press **SELECT** until the **RPM INDICATOR** is illuminated.
2. If the display indicates that the shaker is **OFF**, press the **START/STOP KEY**.
3. Press either **▲** or **▼ KEY** to enter **SET MODE** (the **SET INDICATOR** will illuminate).
4. Set the speed by using the **▲** or **▼ KEY** until the desired setpoint is displayed.
Holding the **▲** or **▼ KEY** will cause the setting to change more rapidly.



NOTE:

The setpoint may be changed during a run without stopping the shaker by following steps 2-4 above. During speed changes, a visual alarm (flashing RPM INDICATOR) will flash and an audible alarm will sound until the speed returns to within 5 rpm of the setpoint.

6.3 Checking a Setpoint

1. Press **SELECT** until the desired indicator is illuminated.
2. Press either **▲** or **▼ KEY** to enter the **SET MODE** and display the current setpoint.



CAUTION!

Holding the **▲** or **▼** key for more than 0.5 seconds causes the speed setpoint to change. Should this occur, resetting will be necessary.

6.4 Timed Functions

The shaker may be programmed to automatically stop after a preset time period of 0.1 hour - 99.9 hours. There must be power to the shaker in order to set the timer. However, a timed run can be initiated while the unit is either shaking or stopped.

To set the timer:

1. Press the **SELECT KEY** until the **HRS INDICATOR** is illuminated.
2. Press either **▲** or **▼ KEY** to enter the **SET MODE** and set between 0.1 - 99.9 hours.
3. While the **SET INDICATOR** is illuminated, press the **START/STOP KEY** to program the time (and start the run). The **TIME INDICATOR** will light and remain on for the duration of the run. At the end of the timed run the display will read **OFF**, the **TIME INDICATOR** will flash and the audible alarm will “beep”.

To disable the visual alarm (flashing **TIME INDICATOR**), press the **SELECT KEY** and change to any other function.

To cancel the timer without stopping the shaker:

Repeat steps 1 and 2. Then immediately press the **START/STOP KEY**. The **TIME INDICATOR** will cease to flash and the display will read **OFF**.

6.5 Alarm Functions

The C-25 and C-25KC shakers have an audible alarm which is activated at predetermined times. To deactivate the alarm:

1. Press **SELECT** until the **HRS INDICATOR** is illuminated.
2. Simultaneously press the **▲** and **▼ KEYS**. The SET and MAINT INDICATORS will flash.
3. While the **SET** and **MAINT INDICATORS** are flashing press the **START/STOP KEY**.

The alarm may be reactivated by repeating steps 1-3. The **MUTE INDICATOR** will illuminate.

6.6 Temperature Setpoint

Press the **SELECT KEY** until the function **°C INDICATOR** illuminates. The temperature can be set from 7°C above (for C-25) and 15°C below (for C-25KC) the current ambient temperature up to 60.0°C. Increasing or decreasing the setpoint is accomplished with the **▲** or **▼ KEY**.

During operation, if the temperature of the chamber is more than 1.0°C higher or lower than the temperature setpoint, an alarm is triggered. This alarm consists of a flashing **°C INDICATOR** and audible beep. The alarm will automatically deactivate as the unit achieves the set temperature.

If desired, the temperature control system of the C-25KC may be shut off during set-up for special investigations.

1. To deactivate the temperature control system press and hold the **▼ KEY** until the setpoint is at 4.0°C.
2. Holding the **▼ KEY**, press the **START / STOP KEY**.
3. The temperature setpoint display shows **OFF** and neither the heater nor the refrigeration system will be activated.
4. To reactivate the temperature controller, press the **▲ KEY** until the desired temperature setpoint is displayed.

6.7 Total Running Time

The control modules of the C-25 and C-25KC shaker totalize the time the shaker has been “ON” to track hours of usage. To display the accumulated running time:

1. Press **SELECT** until the **HRS INDICATOR** is illuminated.
2. Simultaneously press the **▲** and **▼ KEYS**.

The **SET** and **MAINT INDICATORS** will flash and the accumulated running time will be displayed in hundreds of hours (i.e., “02” equals 200 hours; “102” equals 10,200 hours). This display will continue for 10 seconds and then default to the previous mode readout.

6.8 Maint Indicator

After 10,000 hours of operation, the **MAINT INDICATOR** will illuminate. Preventive maintenance is recommended at this point.

To deactivate the **MAINT INDICATOR**:

1. Press **SELECT** until the **HRS INDICATOR** is illuminated.
2. Simultaneously press the **▲** and **▼ KEYS**.
3. Press the **▼ KEY**.

6.9 Power Failure

In the event of a power failure, the C-25 and C-25KC shakers are equipped with an automatic restart function.

If the shaker was in operation prior to the power interruption, the shaker will begin to operate at its last entered setpoint. The **LED DISPLAY** will flash indicating that a power failure has occurred. Press any key to cease the flashing in the display.

7 PREVENTIVE MAINTENANCE



WARNING!

Always turn off the shaker and disconnect the power cord from the power supply **BEFORE** performing any maintenance on the unit.

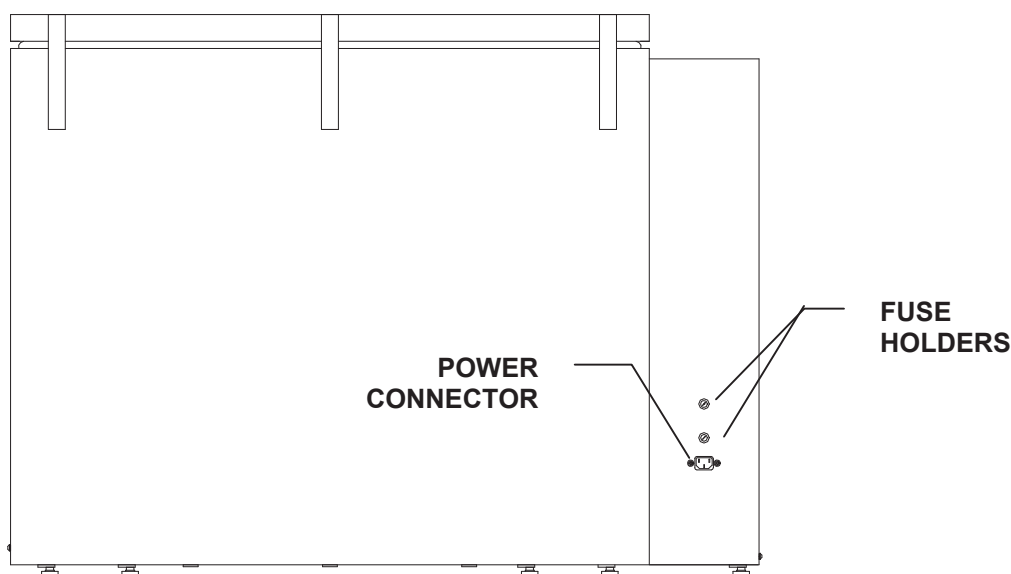
7.1 Cleaning External Surfaces

The unit may be cleaned using a damp cloth or any standard, household or laboratory cleaner to wipe down its outer surfaces. Do not use abrasive or corrosive compounds to clean this instrument, as they may damage the unit and void the warranty.

7.2 Fuse Replacement

The C-25 and C-25KC require two electrical fuses. They are housed in the fuse holders located on rear panel of the unit near the **POWER CORD CONNECTOR** (*see Figure 4, repeated below*):

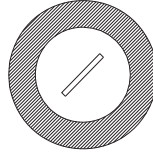
Figure 4: C-25 and C-25KC Rear Panel



To check or replace a fuse:

1. Set the **ON/OFF SWITCH** to off and disconnect the **POWER CORD** from the power source.
2. Insert a small flat bladed screwdriver into the fuse holder groove and turn counter-clockwise until it disengages and the fuse holder springs free.

Figure 6: Fuse Holder (detail)



3. Check the fuse and if it has failed, replace the fuse.

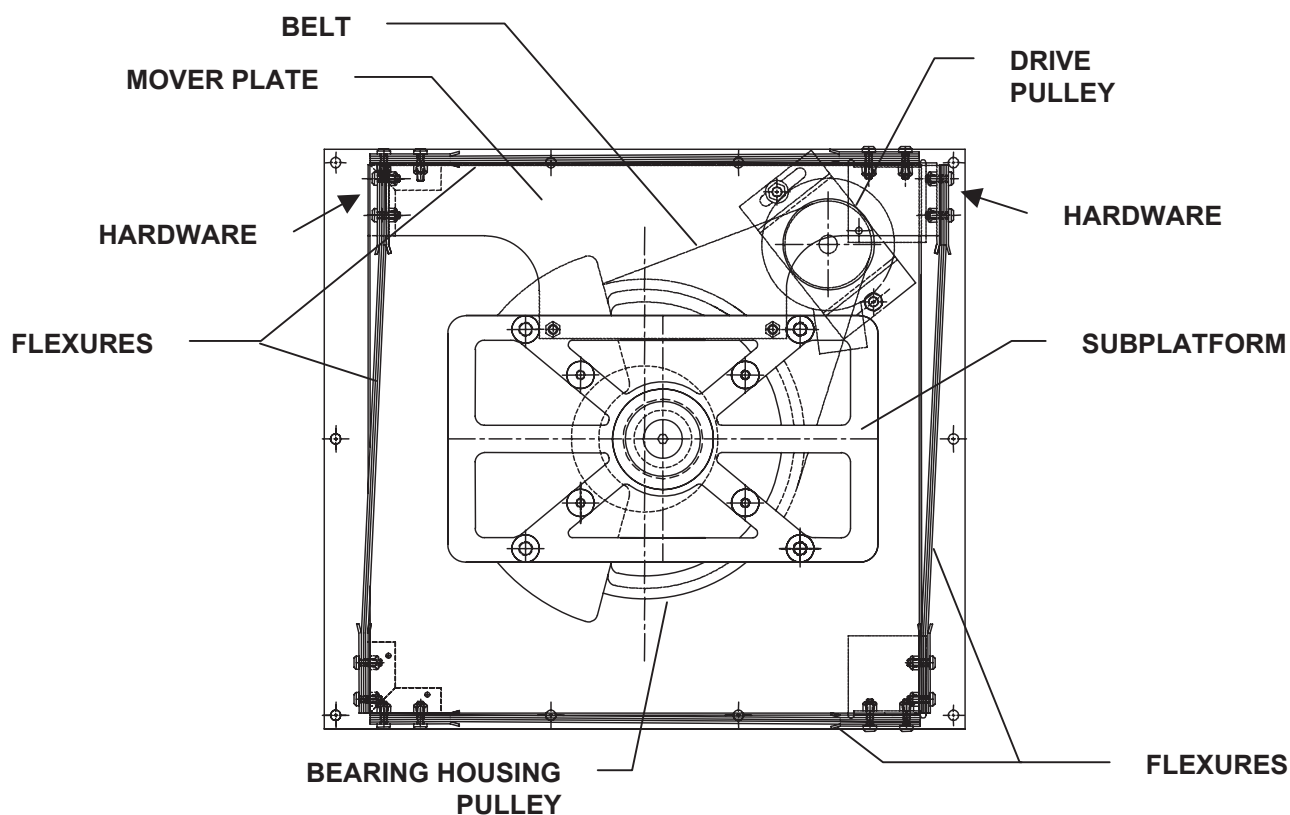
7.3 Belt Replacement

To replace the shaker's drive belt:

1. Turn off the unit, and disconnect the power cord from the power source.
2. Open the lid.
3. Remove the platform, setting the platform and platform screws aside.

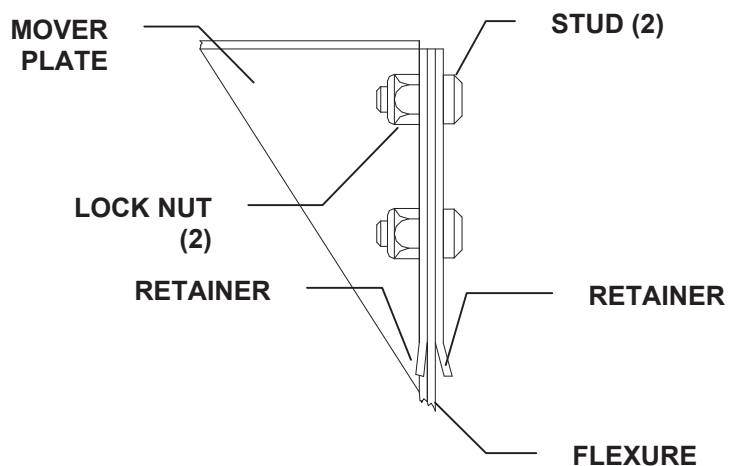
Refer to Figures 7 & 8 on the following page as you continue the procedure.

Figure 7: Belt Removal



4. Loosen and remove the hardware that attaches the **FLEXURES** to the **MOVER PLATE** (see Figure 8 below):

Figure 8: Flexure Attaching Hardware (Reverse View)



5. Using your fingers, reach under the **SUBPLATFORM** and move the **BELT** so that it falls off the **DRIVE PULLEY**. Remove the belt from the **BEARING HOUSING PULLEY**.

6. Grab the belt from underneath the sub-platform, pull it forward and over one corner of the subplatform. Repeat for the other corner until the belt clears the subplatform, but is constrained by the mover plate.
7. Slide the belt to one of the unattached sides of the mover plate and pull it through the opening.
8. Slide the belt to the other side of the mover plate, pull it through the opening, and remove it from the unit.
9. Install the replacement belt in similar fashion.
10. Reattach the **FLEXURES** to the **MOVER PLATE**.
11. Reinstall the platform if desired, and close the lid.
12. Reconnect the power cord to the unit.

8 TROUBLESHOOTING

If any problems occur with your shaker, **do not attempt to perform any service on the unit other than specified in this manual.** Unauthorized servicing may void the warranty. Please contact your local NBS Sales Order Department

In any correspondence with NBS, please refer to the Model Number and Serial Number of your unit. This information is on the **ELECTRICAL SPECIFICATION PLATE**, located on the side panel of the unit near the **ON/OFF SWITCH**.

THIS PAGE IS INTENTIONALLY BLANK

9 REPLACEMENT PARTS & ACCESSORIES

When ordering replacement or accessory parts, or requesting service information, please provide the Model Number and Serial Number of your shaker. This information is on the **ELECTRICAL SPECIFICATION PLATE**, located on the side panel of the unit.

9.1 Replacement Parts

Table 2: Service Parts

Part Description	Quantity Required	NBS Part Number
V-Belt*	1	R-334
Housing Extractor Plate*	1	M1191-9300
3/8-16 NC x 1 1/4" long flat head Allen screw*	3	S1127-3206
Fuse, Slo Blo® 1.6 A, 250 V	1	P0380-3532
Fuse, Slo Blo® 0.16 A, 250 V	1	P0380-3710

*needed for belt replacement

9.2 Accessories

Table 3: Platforms

Platform Description	Capacity	NBS Part Number
Universal Platform		
See Table 5 on the following page		M1250-9920
Dedicated Platforms		
50 ml Erlenmeyer Flasks	108	M1191-9908
125 ml Erlenmeyer Flasks	60	M1191-9909
250 ml Erlenmeyer Flasks	40	M1191-9910
500 ml Erlenmeyer Flasks	24	M1191-9911
1 L Erlenmeyer Flasks	15	AG-1
2 L Erlenmeyer Flasks	12	AG-2
2.8 L Fernbach Flasks	6	AG-28
4 L Erlenmeyer Flasks	6	AG-4
6 L Erlenmeyer Flasks	4	AG-6

Table 4: Universal Platform Flask Capacity

Flask Type	Capacity
50 ml Erlenmeyer Flasks	92
125 ml Erlenmeyer Flasks	39
250 ml Erlenmeyer Flasks	30
500 ml Erlenmeyer Flasks	18
1 L Erlenmeyer Flasks	12
2 L Erlenmeyer Flasks	8
2.8 L Fernbach Flasks	6
4 L Erlenmeyer Flasks	6
6 L Erlenmeyer Flasks	4

Table 5: Carriers & Test Tube Racks

Accessory Description	NBS Part Number
Utility Tray with rubber mat for shaking 96 well plates, petri dishes and other labware at low speeds.	AG-00
Angled Test Tube Rack Holder for user-supplied test tube racks that are 4-5 inches (10-13 mm) wide and up to 15 inches (38 mm) long. Capacity: 4 racks/platform.	TTR-210*
Angled Test Tube Rack Spacer for use with TTR-210 to accommodate test tube racks that are less than 5 inches (13 mm) wide and up to 15 inches (38 mm) long.	TTR-215*
Microtiter Plate Carrier, capacity up to 4 microtiter plates	TTR-221*
80-tube (8-11mm Ø) Adjustable Angle Test Tube Rack	M1289-0100⌘
60-tube (12-15mm Ø) Adjustable Angle Test Tube Rack	M1289-0200⌘
42-tube (15-18mm Ø) Adjustable Angle Test Tube Rack	M1289-0300⌘
30-tube (18-21mm Ø) Adjustable Angle Test Tube Rack	M1289-0400⌘
22-tube (22-26mm Ø) Adjustable Angle Test Tube Rack	M1289-0500⌘
20-tube (26-30mm Ø) Adjustable Angle Test Tube Rack	M1289-0600⌘
Microplate Holder, stack 3 deep-well or 9 standard microplates	M1289-0700◇

*Universal Platform Required

⌘ Platform capacity is 7 racks

◇ Platform capacity is 16 racks

10 DRAWINGS

Figure 9: C-25 115 VAC Control Schematic (Overview)

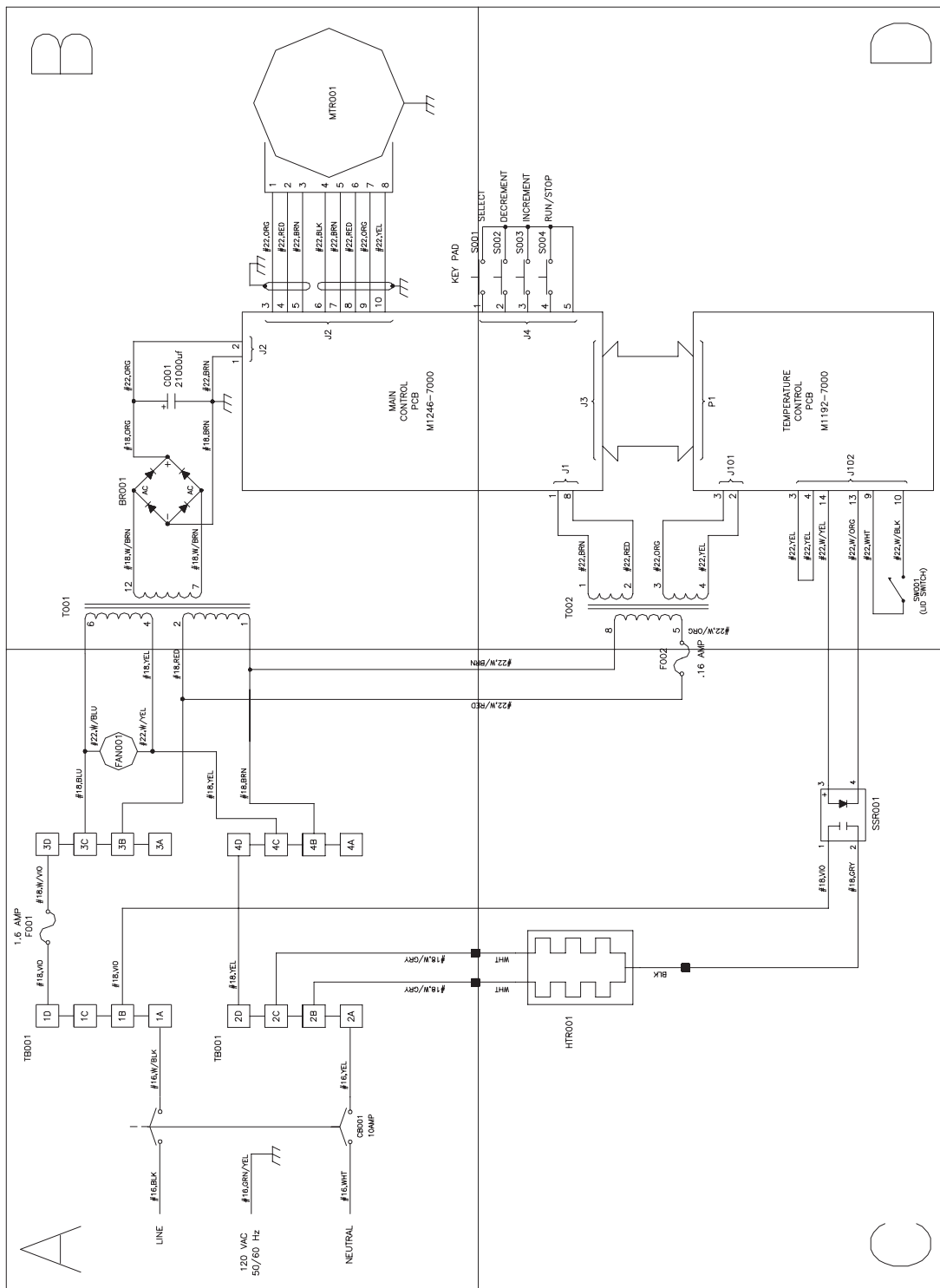


Figure 9a: C-25 115 VAC Control Schematic (Section A)

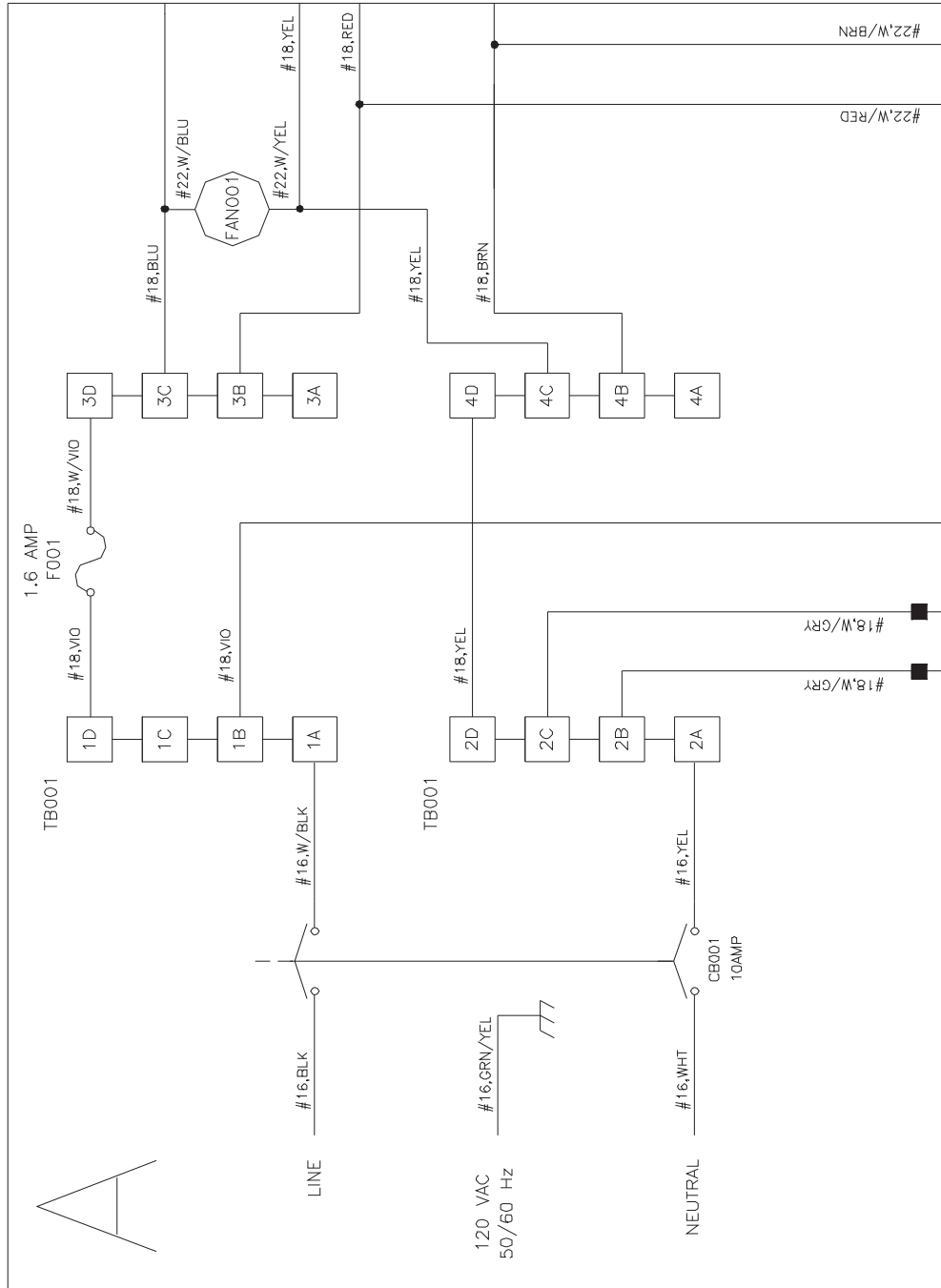


Figure 9b: C-25 115 VAC Control Schematic (Section B)

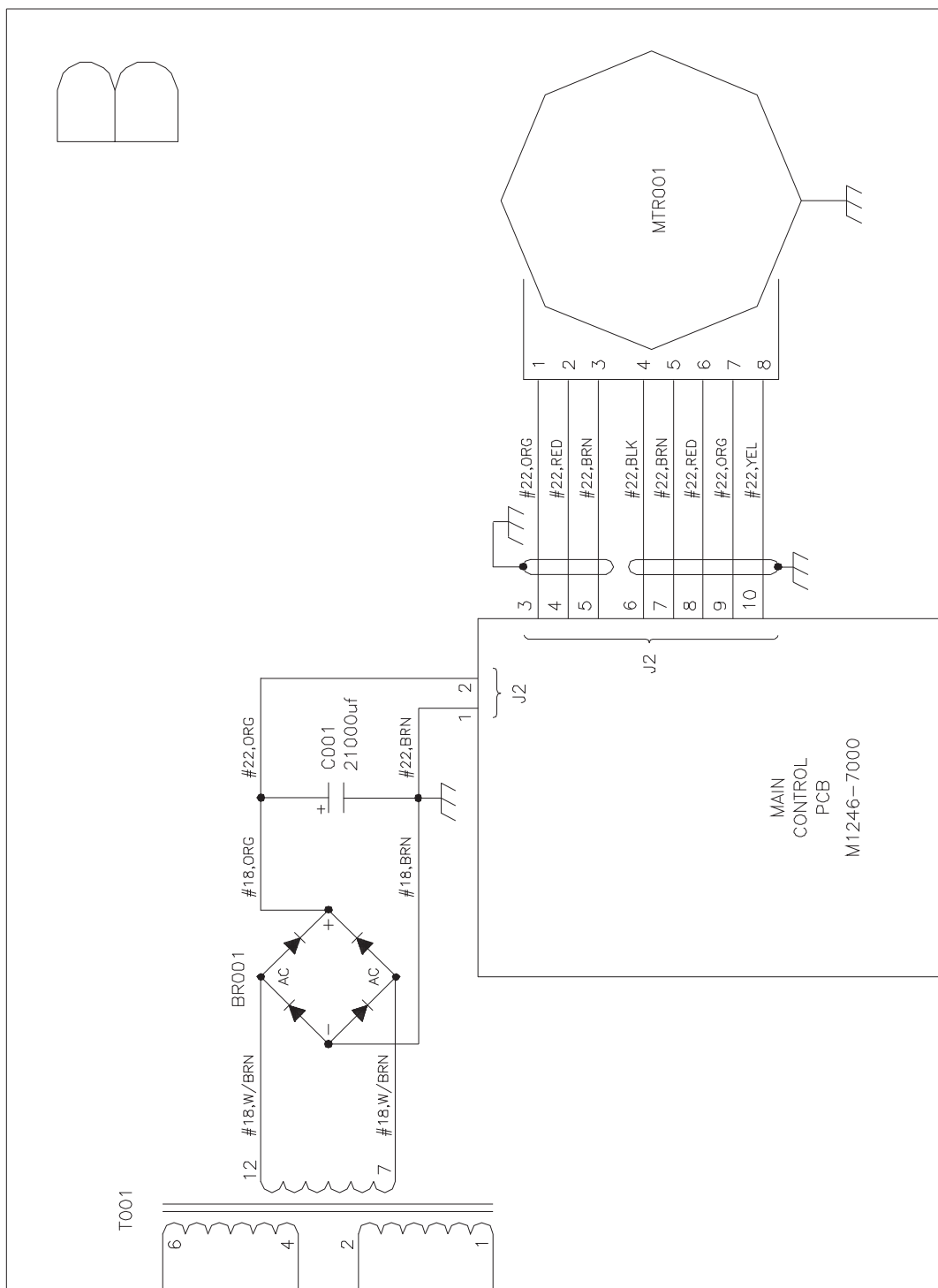


Figure 9c: C-25 115 VAC Control Schematic (Section C)

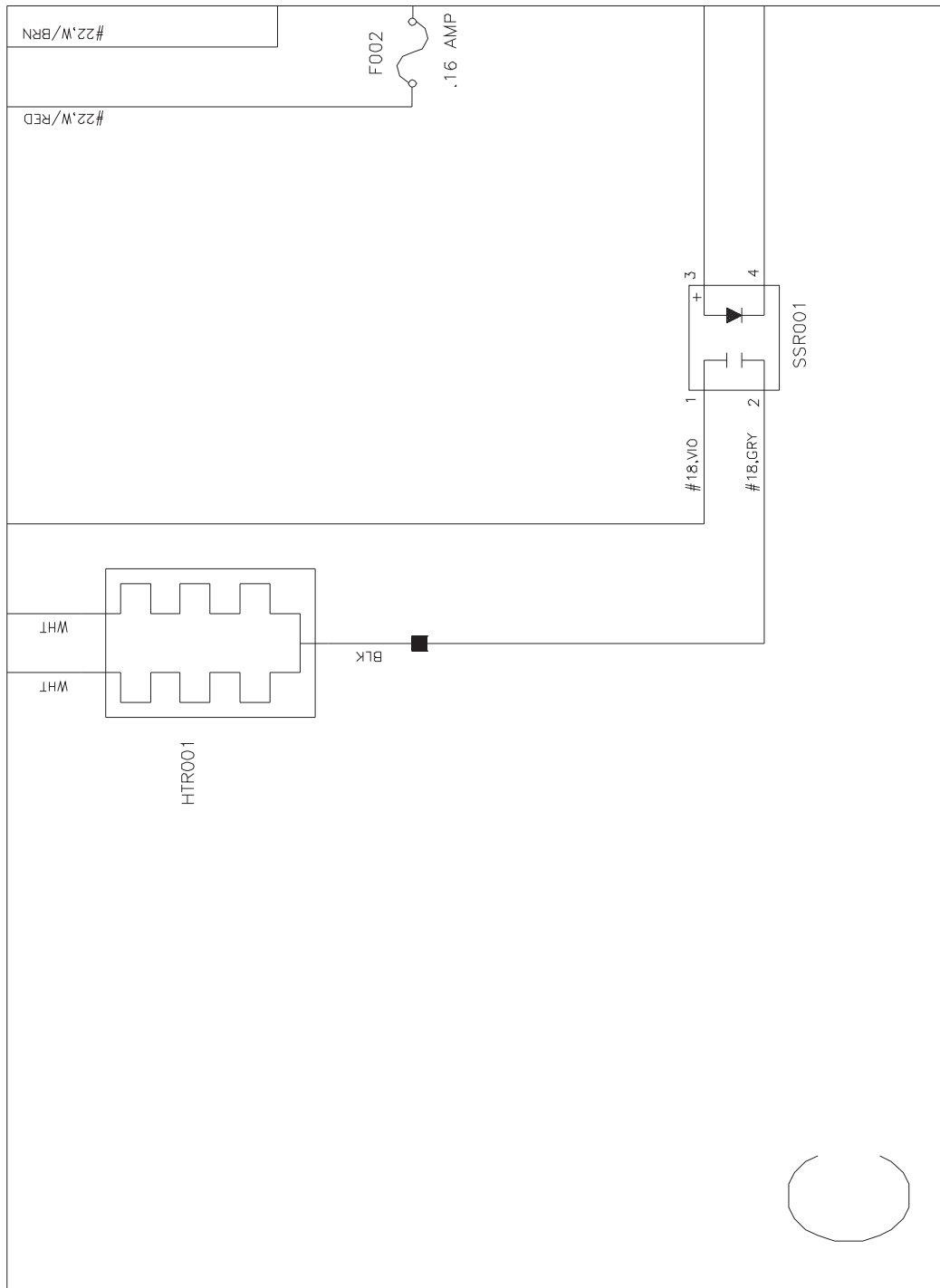


Figure 9d: C-25 115 VAC Control Schematic (Section D)

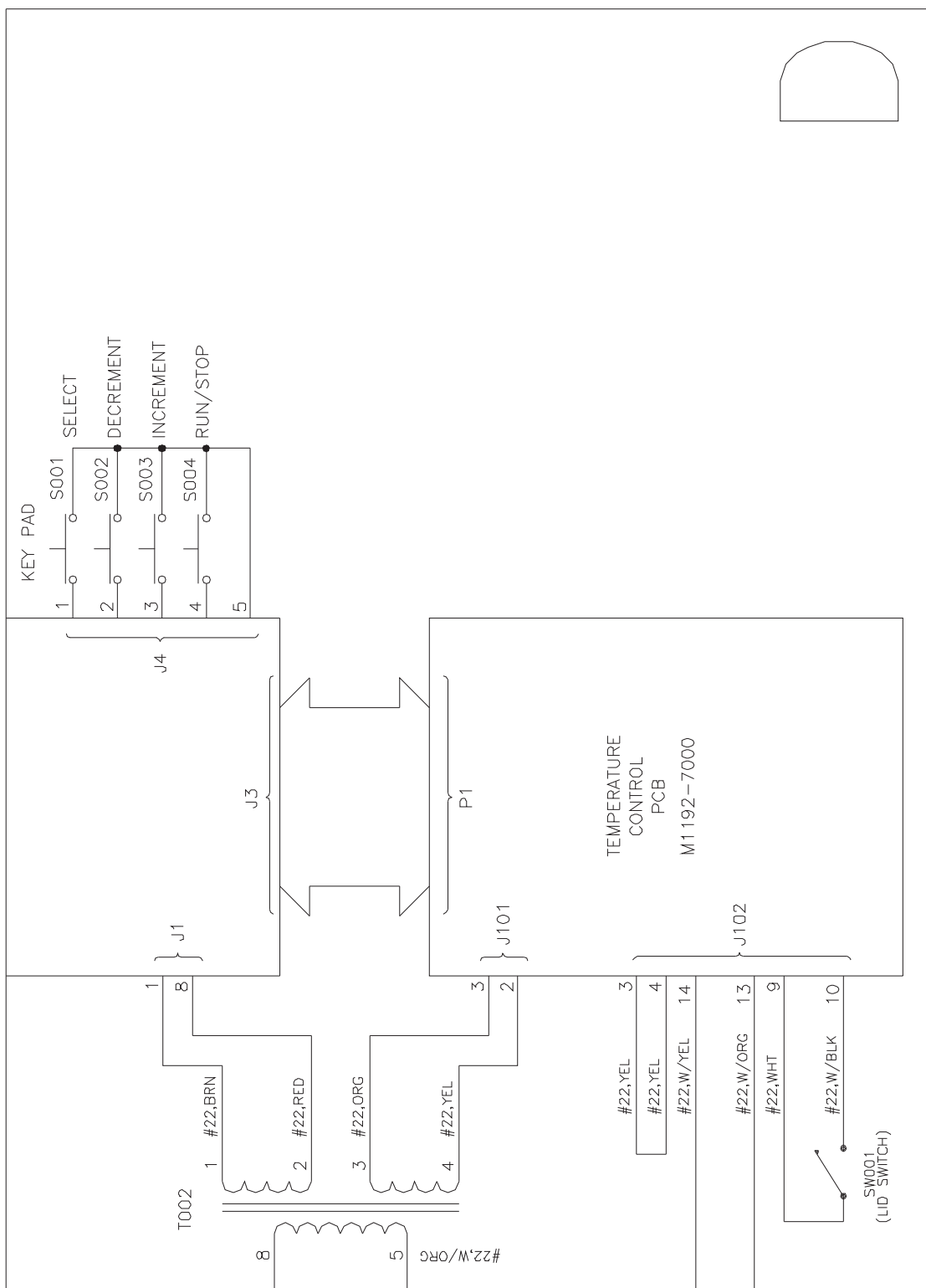


Figure 10: C-25 230 VAC Control Schematic (Overview)

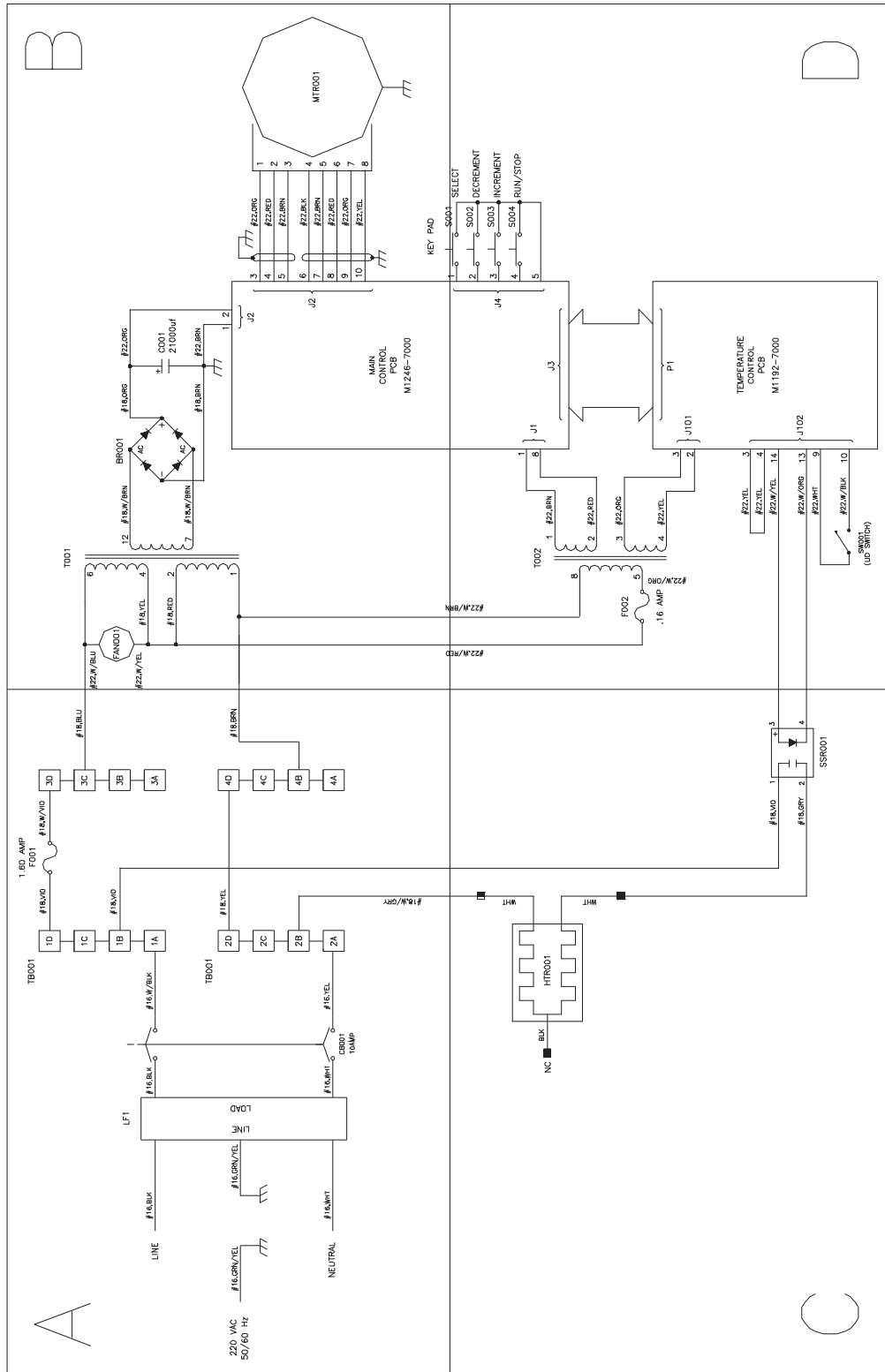


Figure 10a: C-25 230 VAC Control Schematic (Section A)

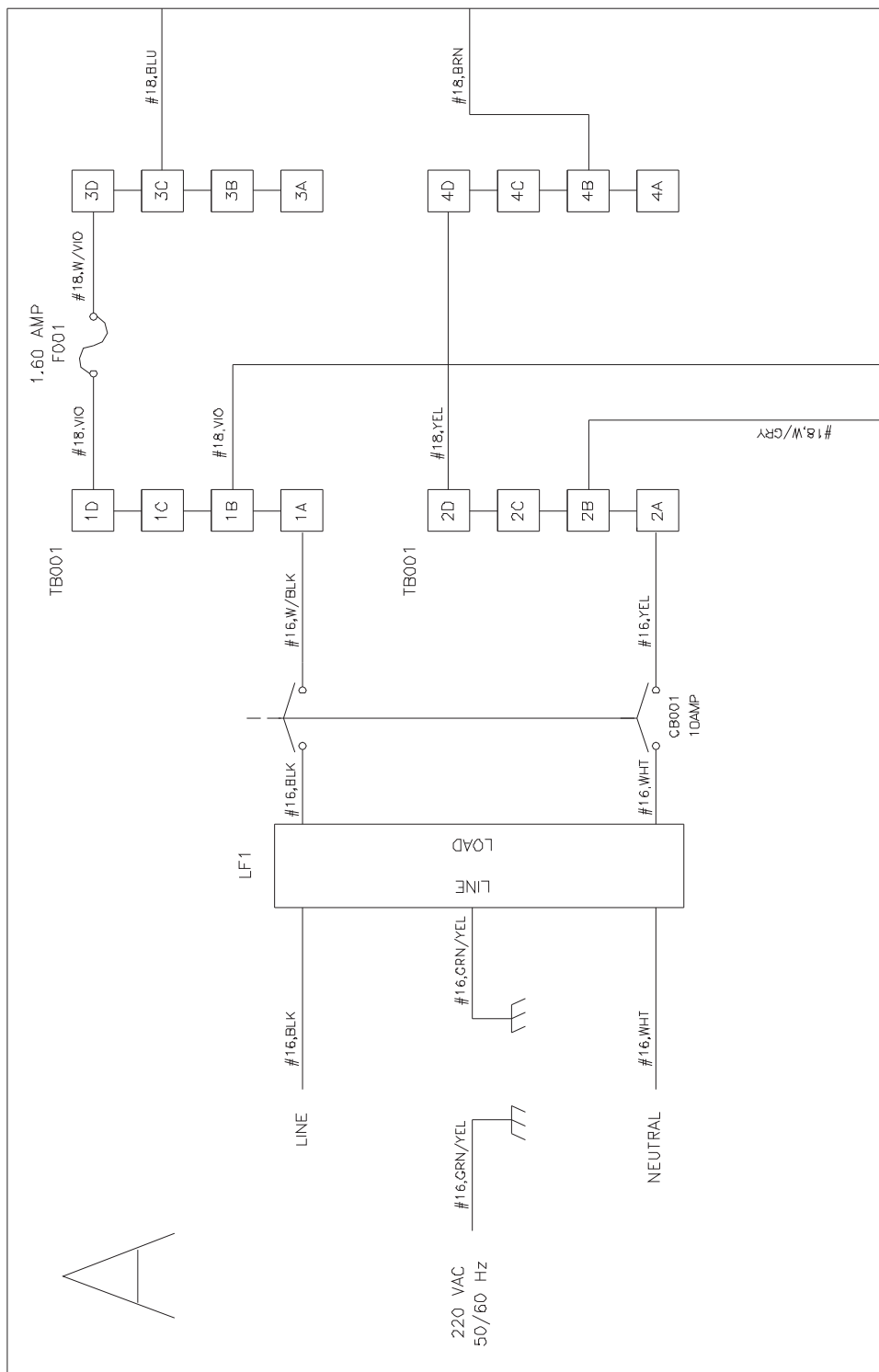


Figure 10b: C-25 230 VAC Control Schematic (Section B)

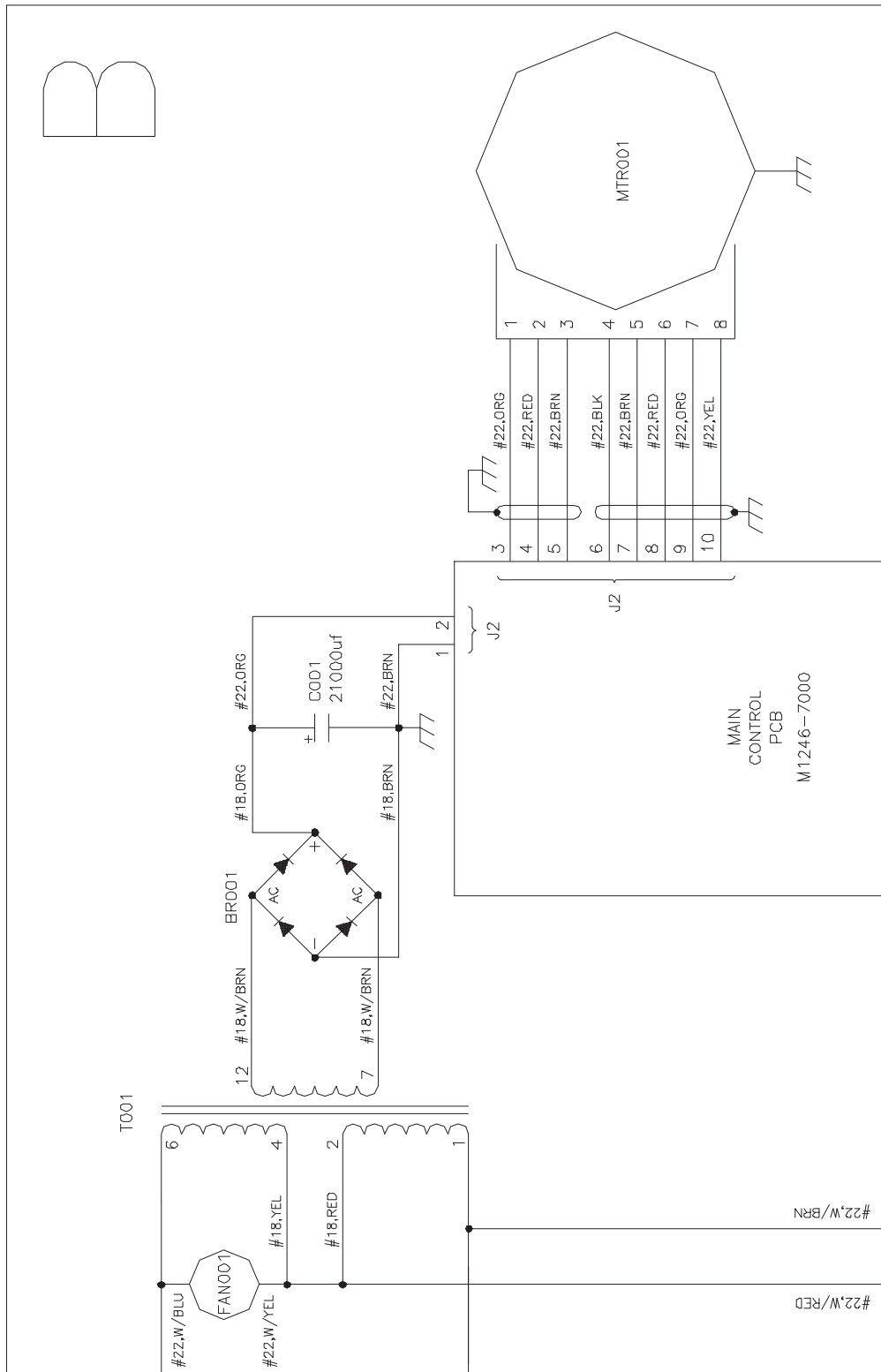


Figure 10c: C-25 230 VAC Control Schematic (Section C)

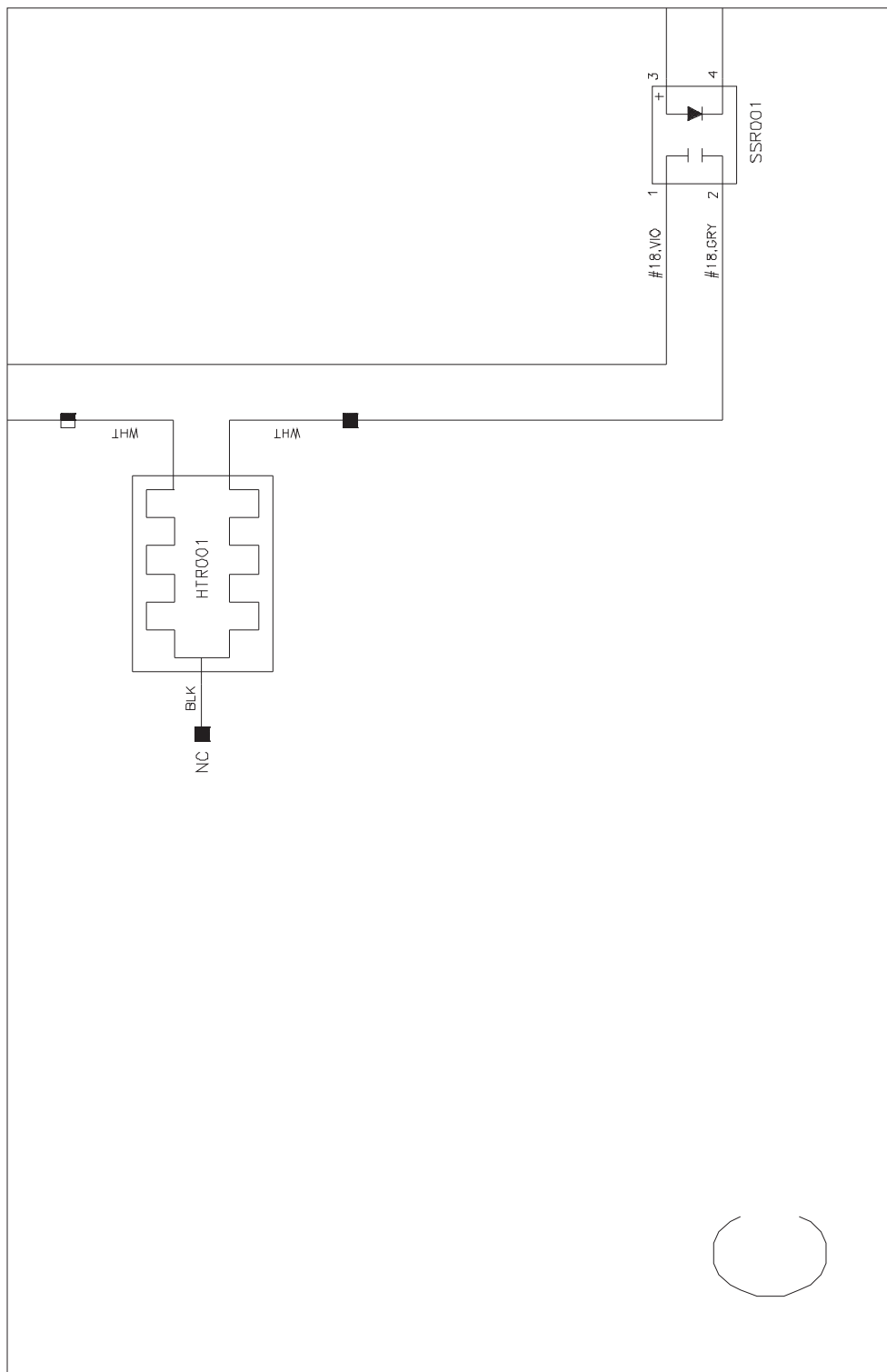


Figure 10d: C-25 230 VAC Control Schematic (Section D)

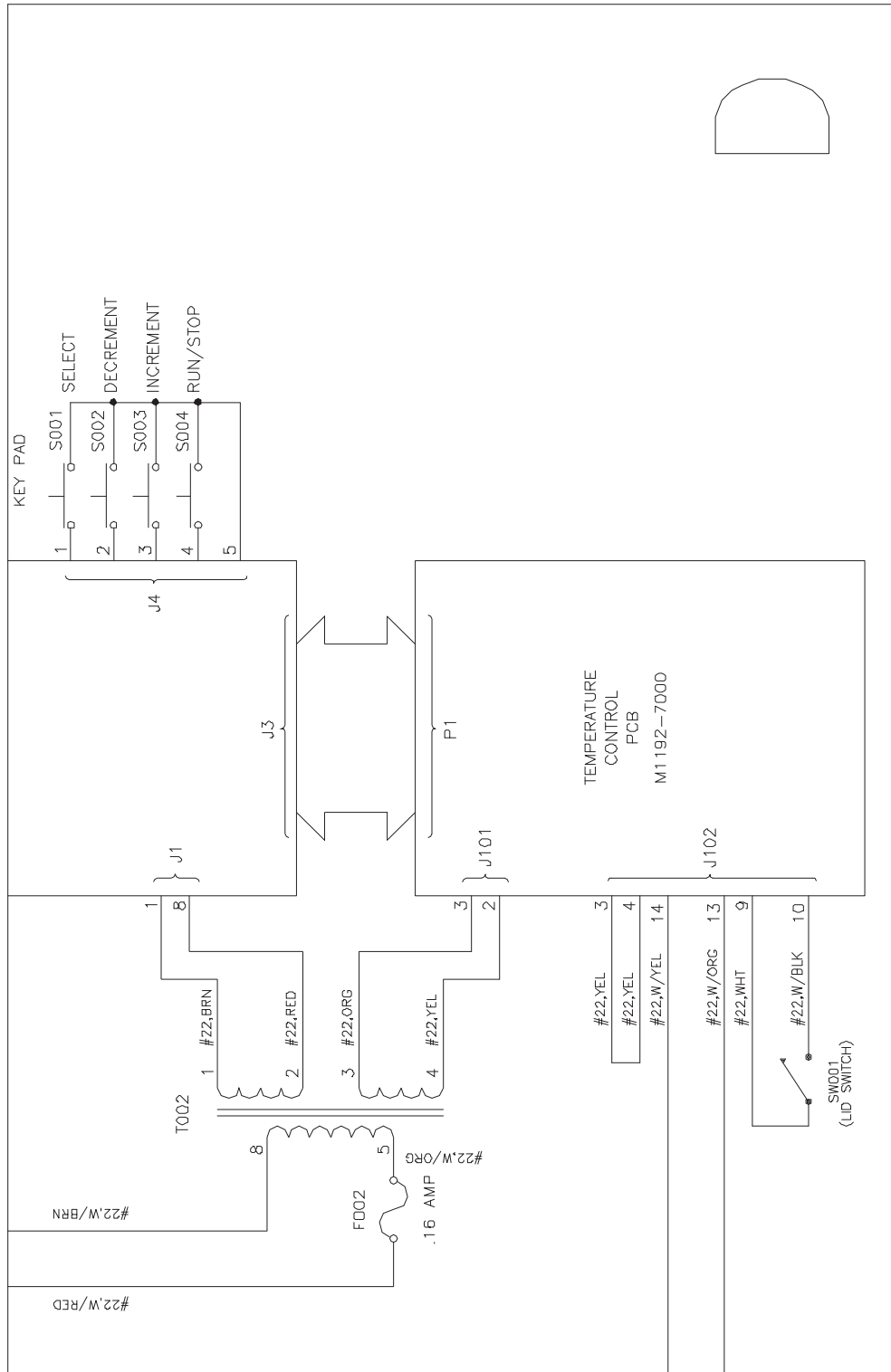


Figure 11: C-25KC 115 VAC Control Schematic (Overview)

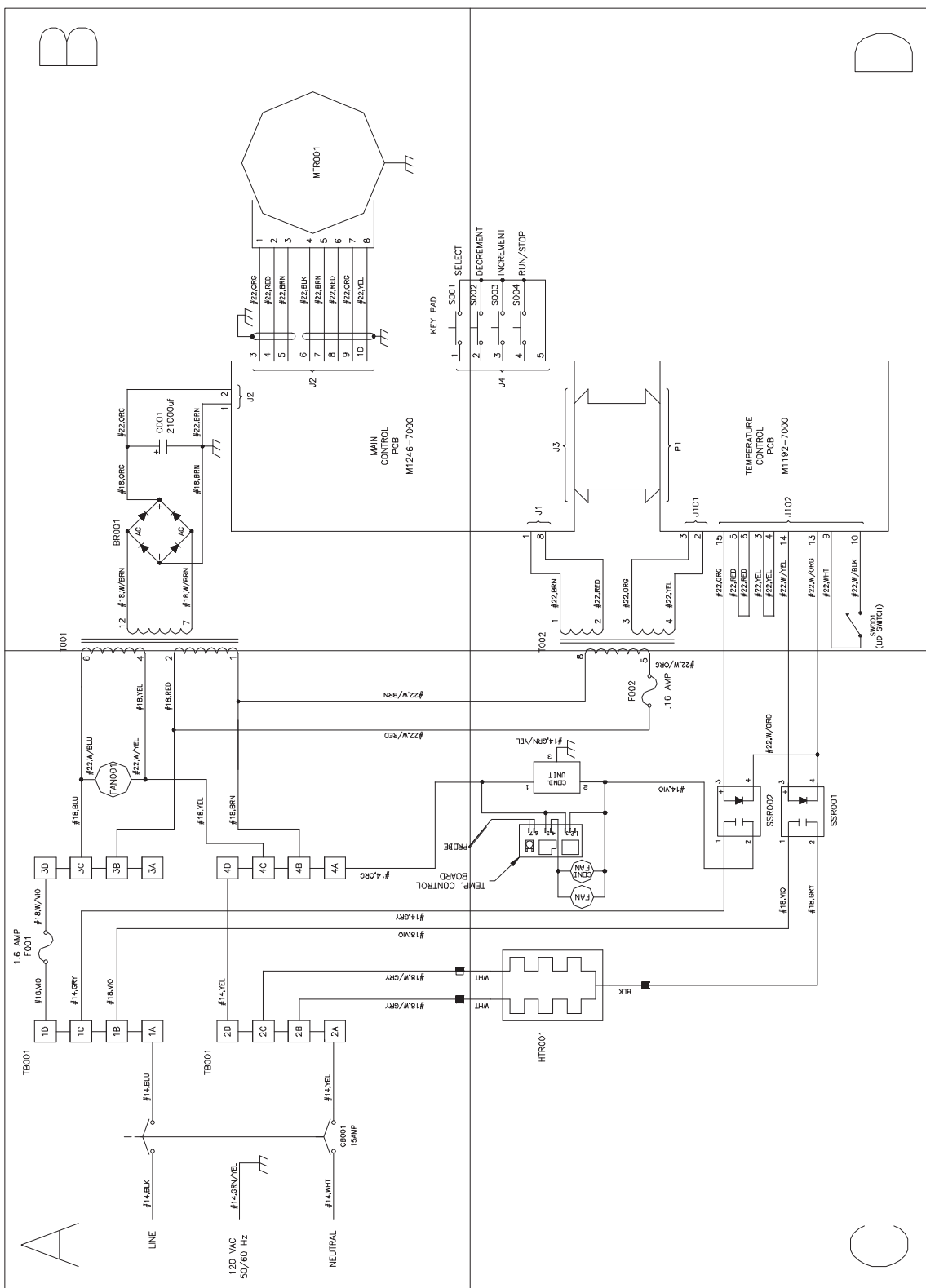


Figure 11a: C-25KC 115 VAC Control Schematic (Section A)

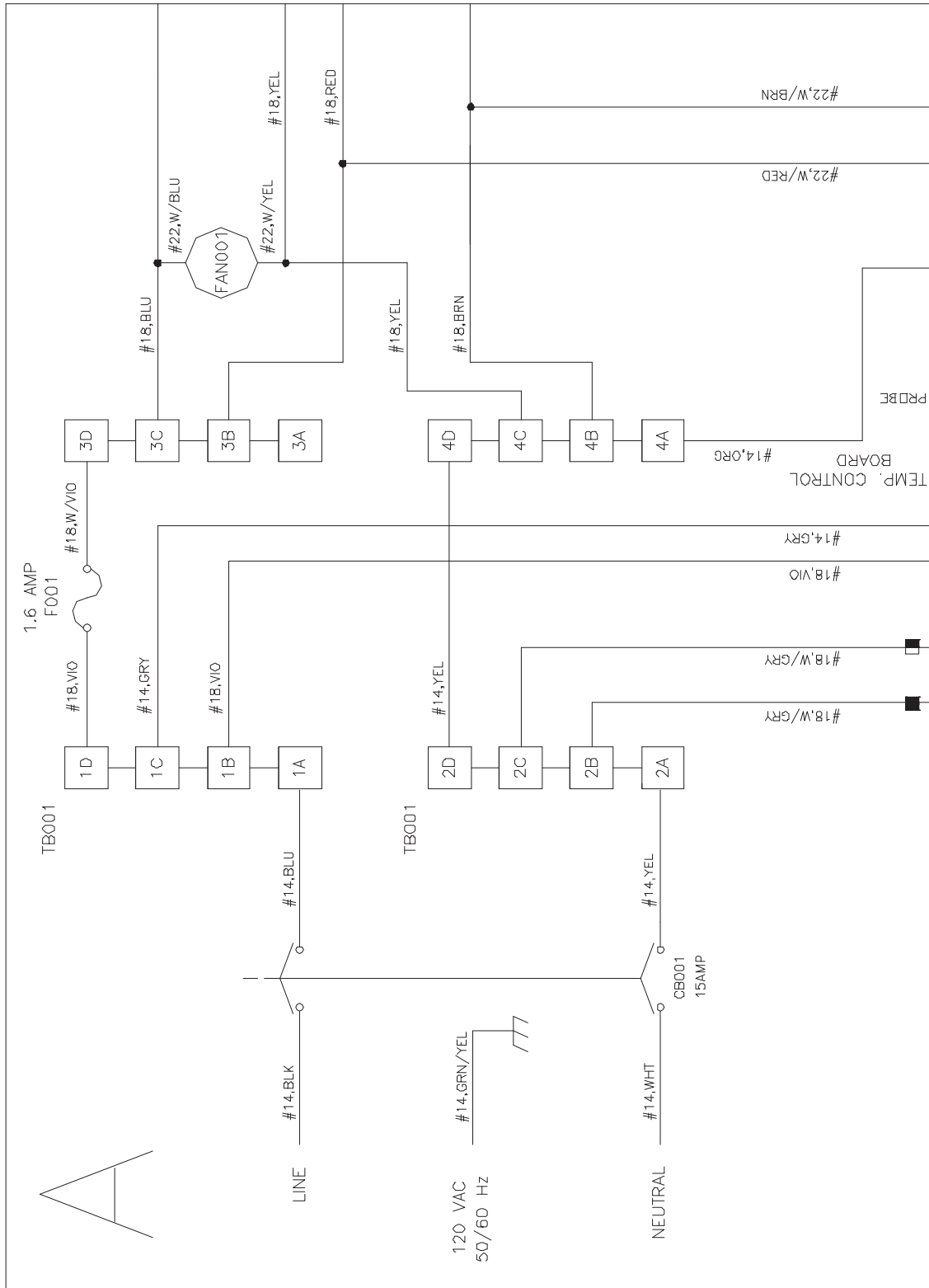


Figure 11b: C-25KC 115 VAC Control Schematic (Section B)

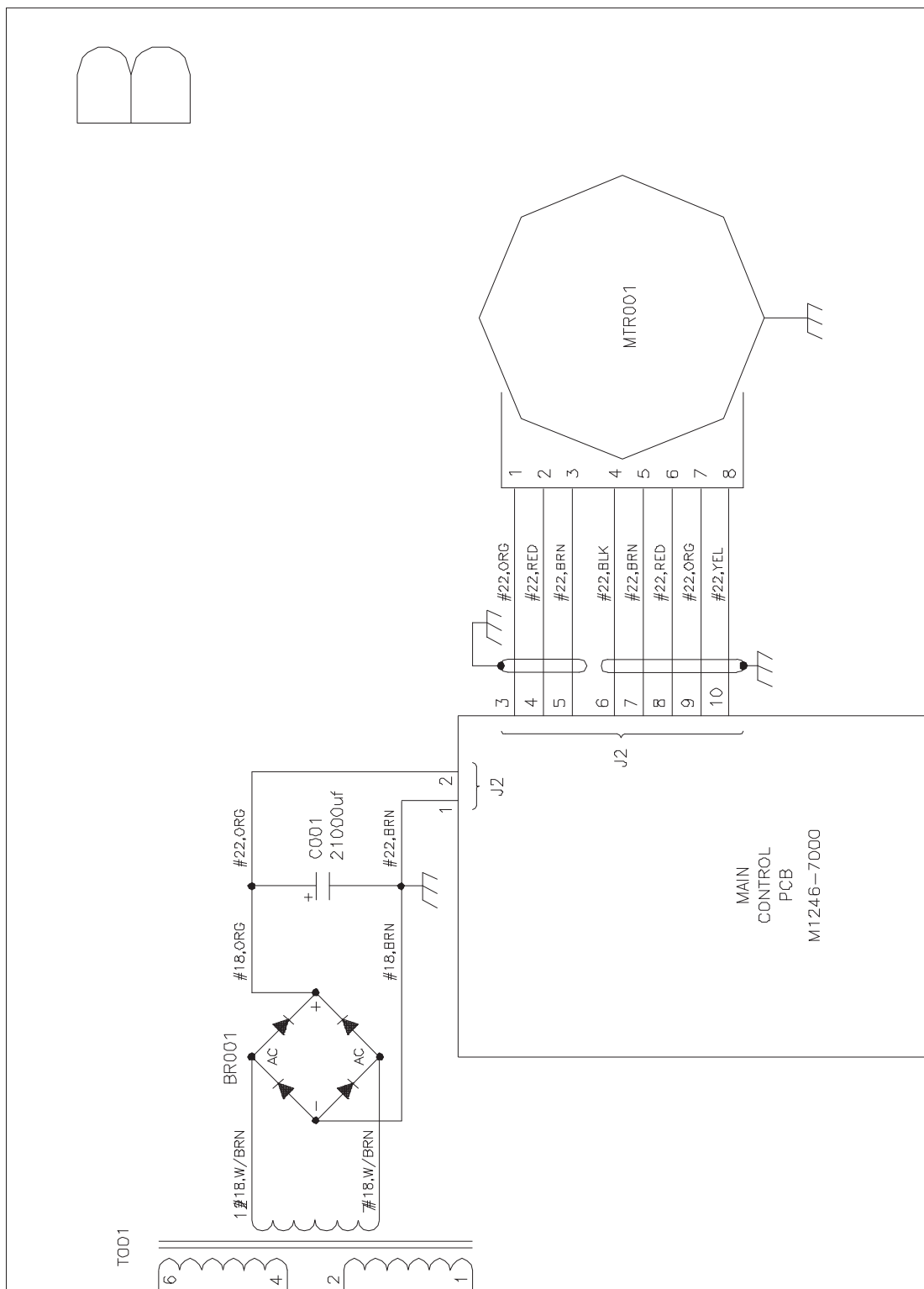


Figure 11c: C-25KC 115 VAC Control Schematic (Section C)

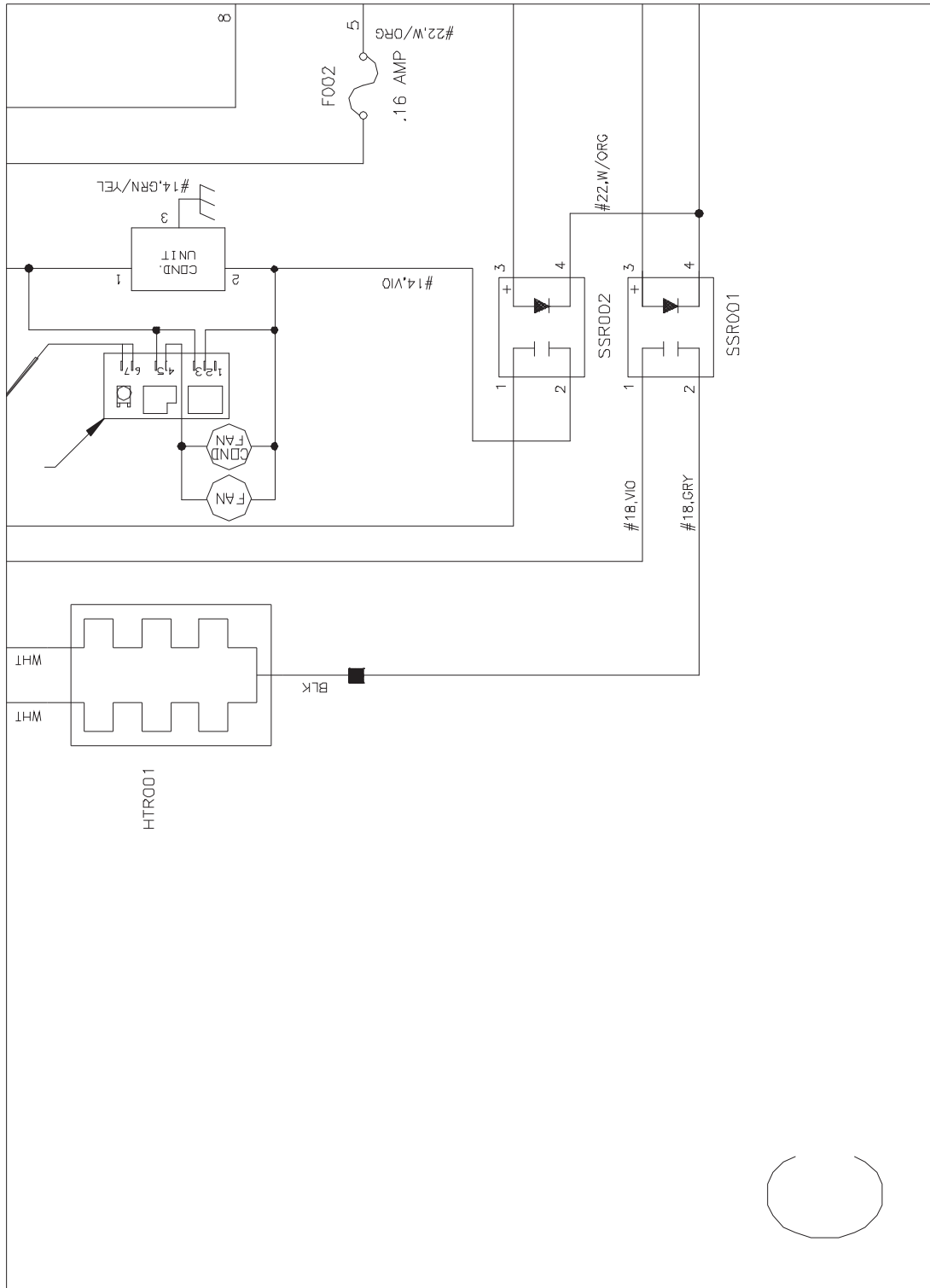


Figure 11d: C-25KC 115 VAC Control Schematic (Section D)

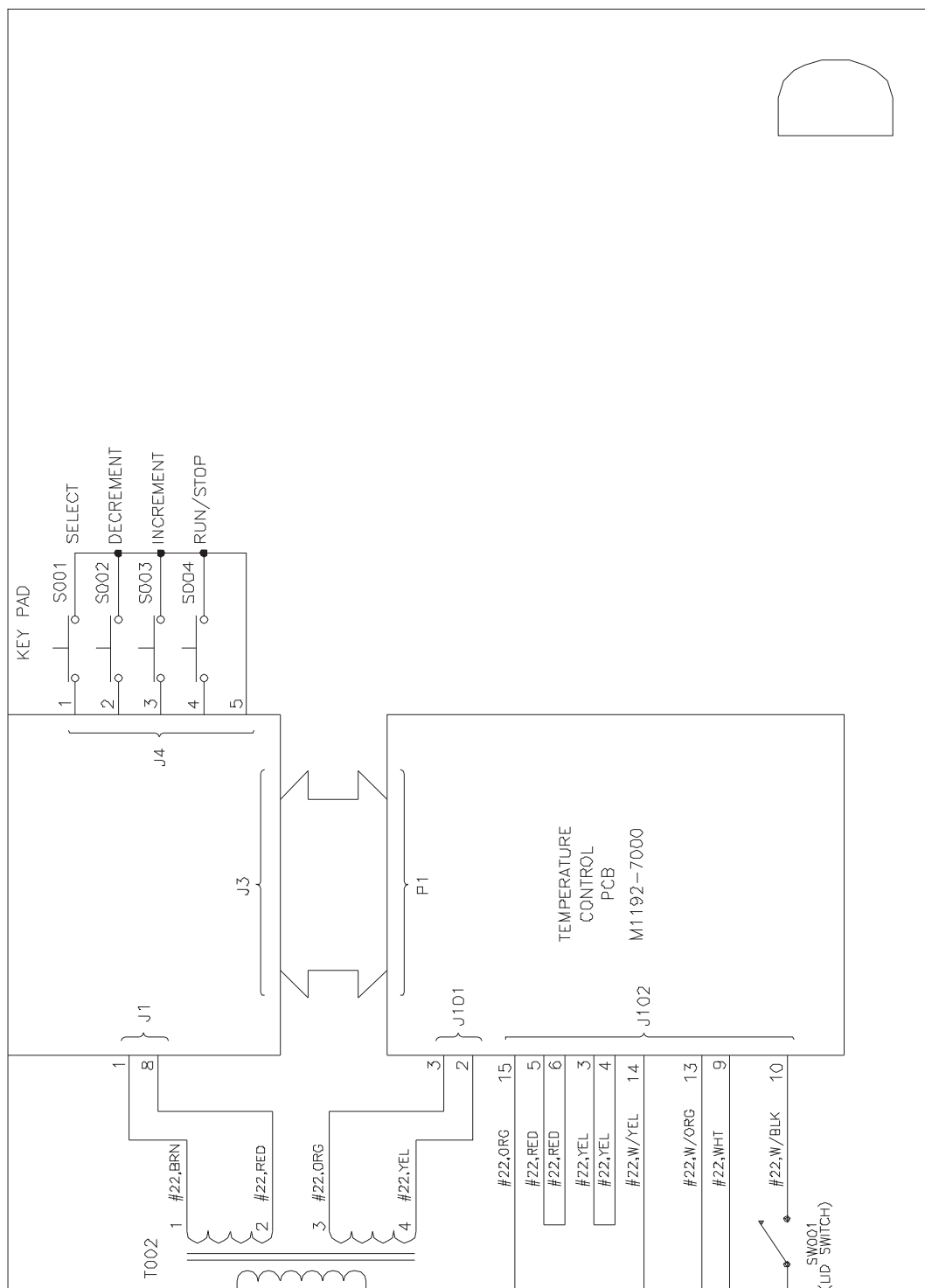


Figure 12: C-25KC 230 VAC Control Schematic (Overview)

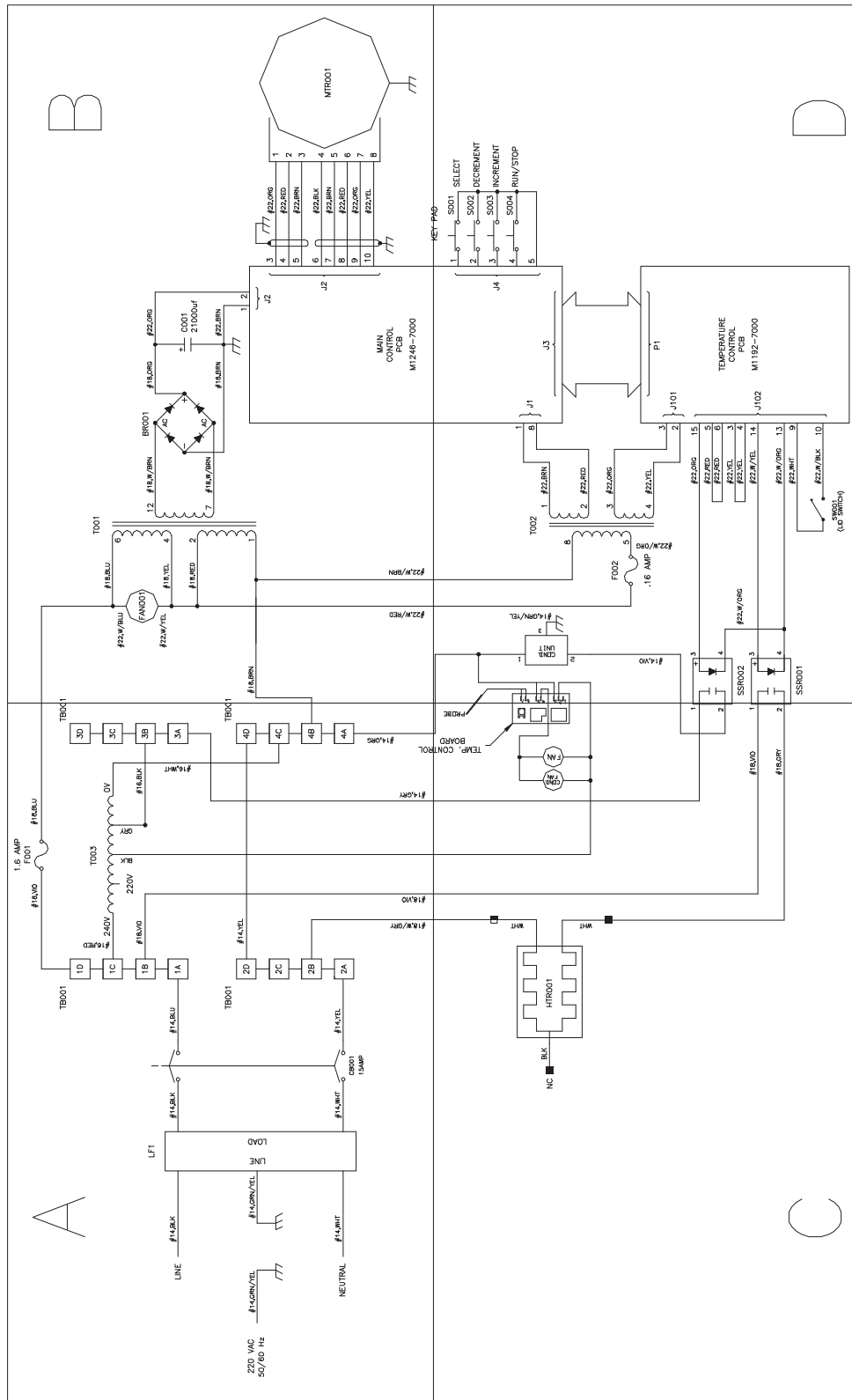


Figure 12a: C-25KC 230 VAC Control Schematic (Section A)

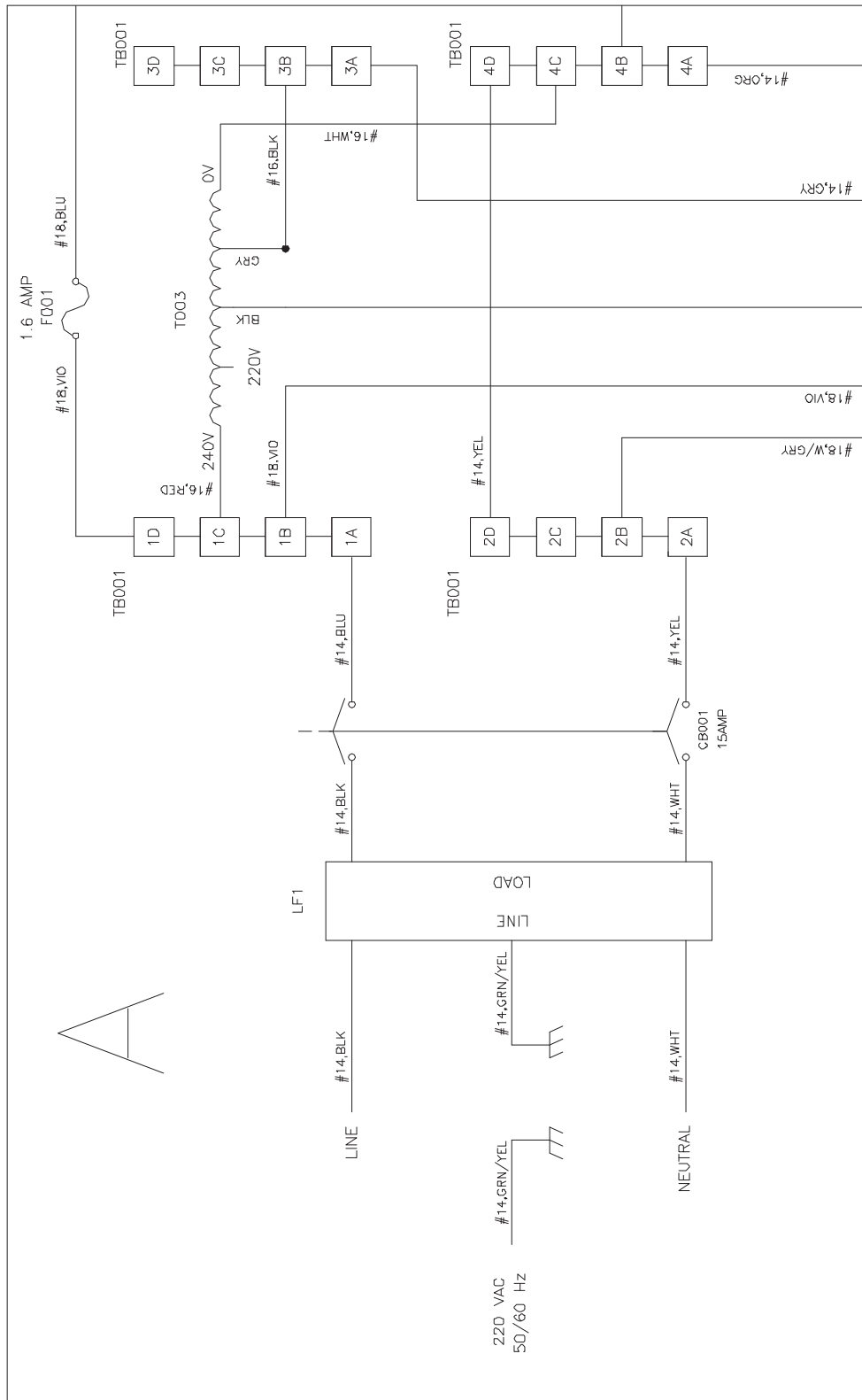


Figure 12b: C-25KC 230 VAC Control Schematic (Section B)

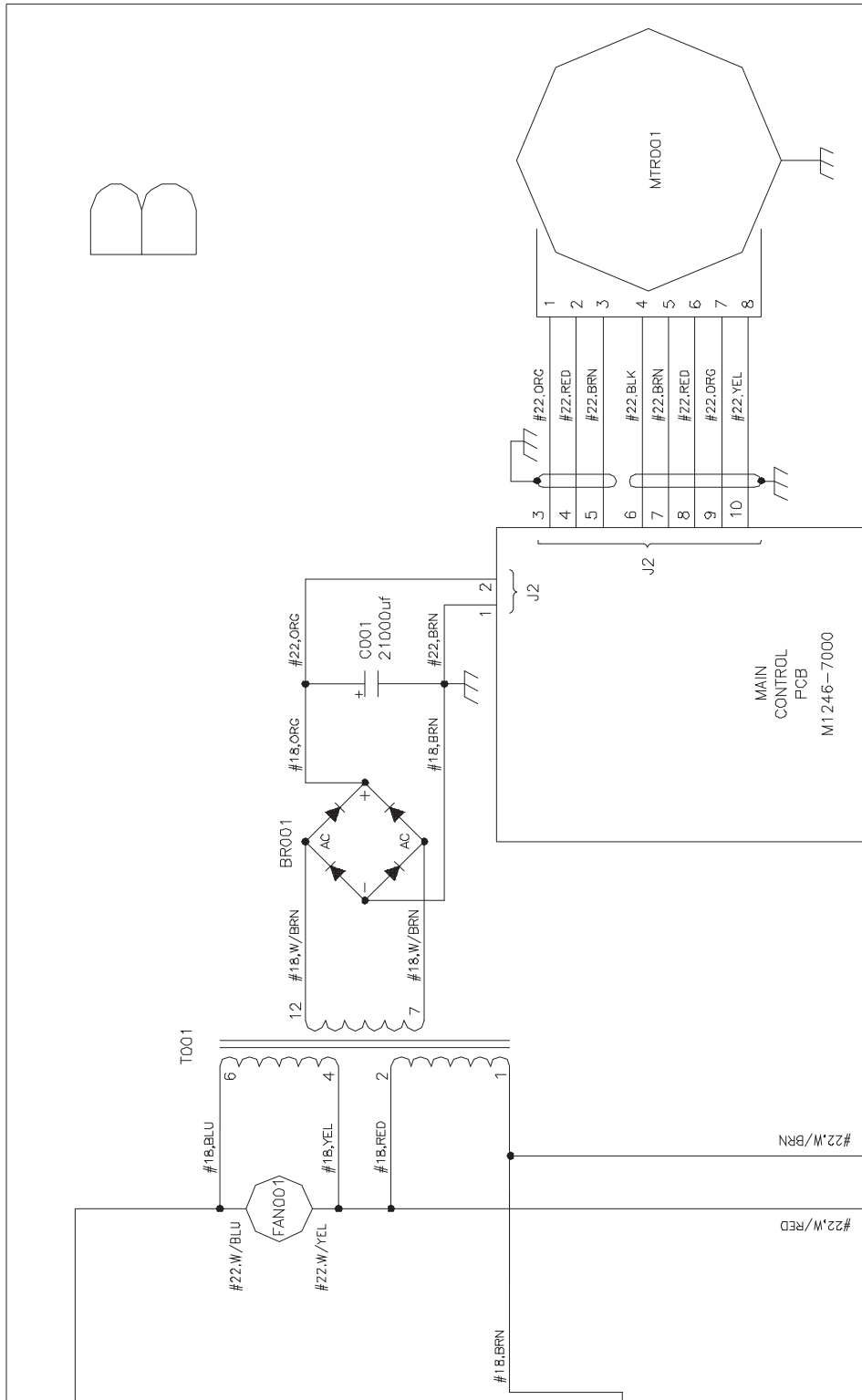


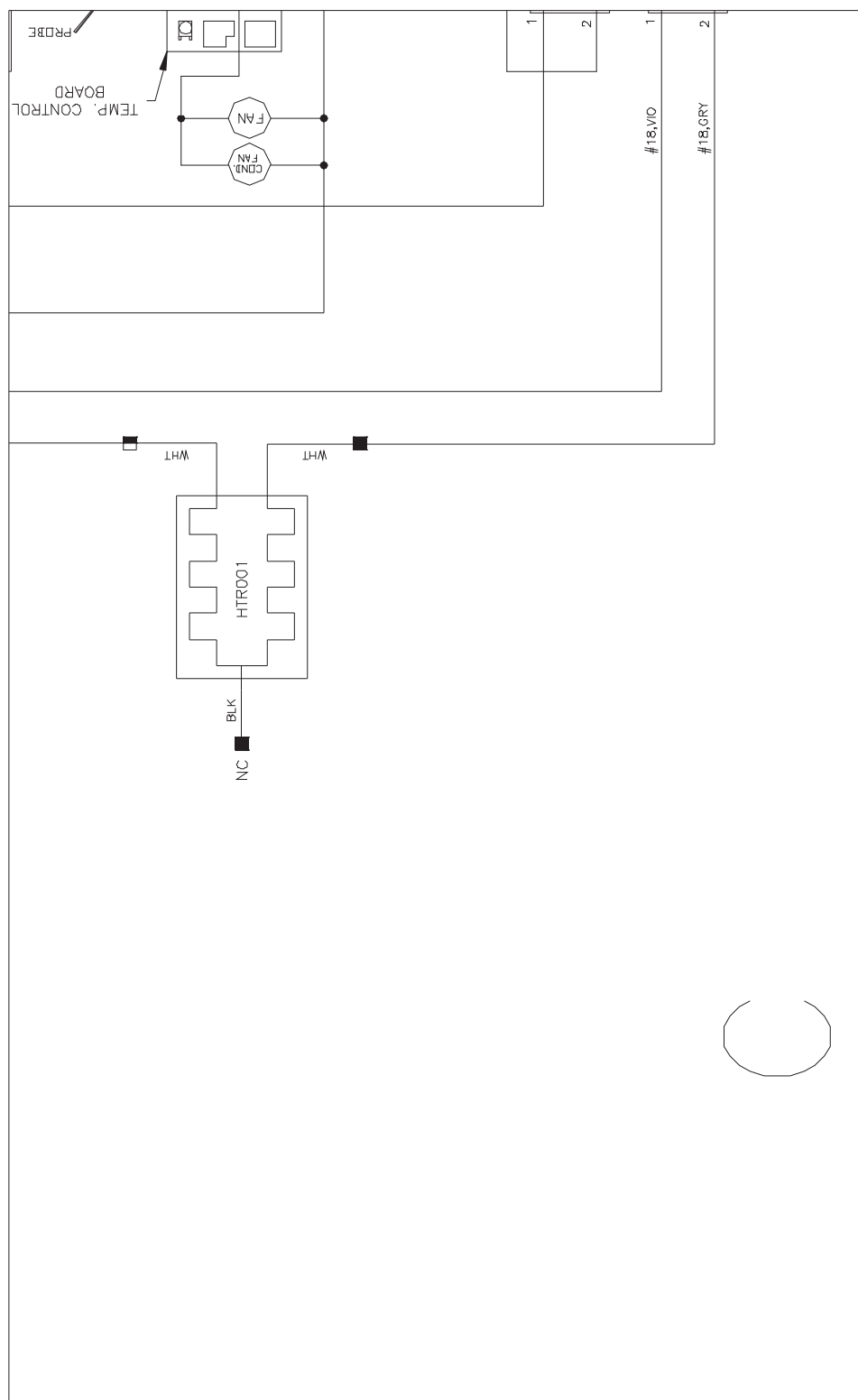
Figure 12c: C-25KC 230 VAC Control Schematic (Section C)

Figure 12d: C-25KC 230 VAC Control Schematic (Section D)

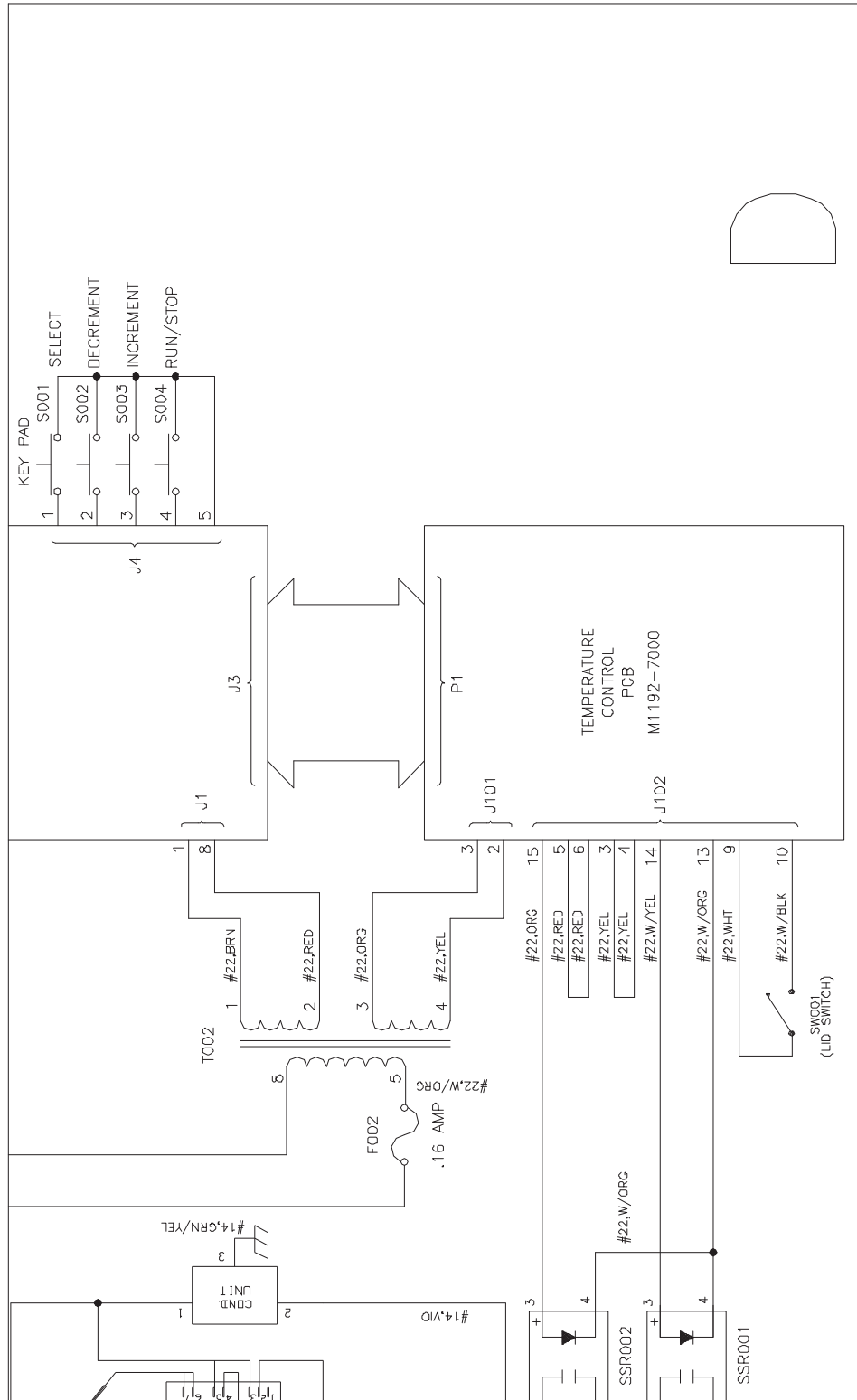
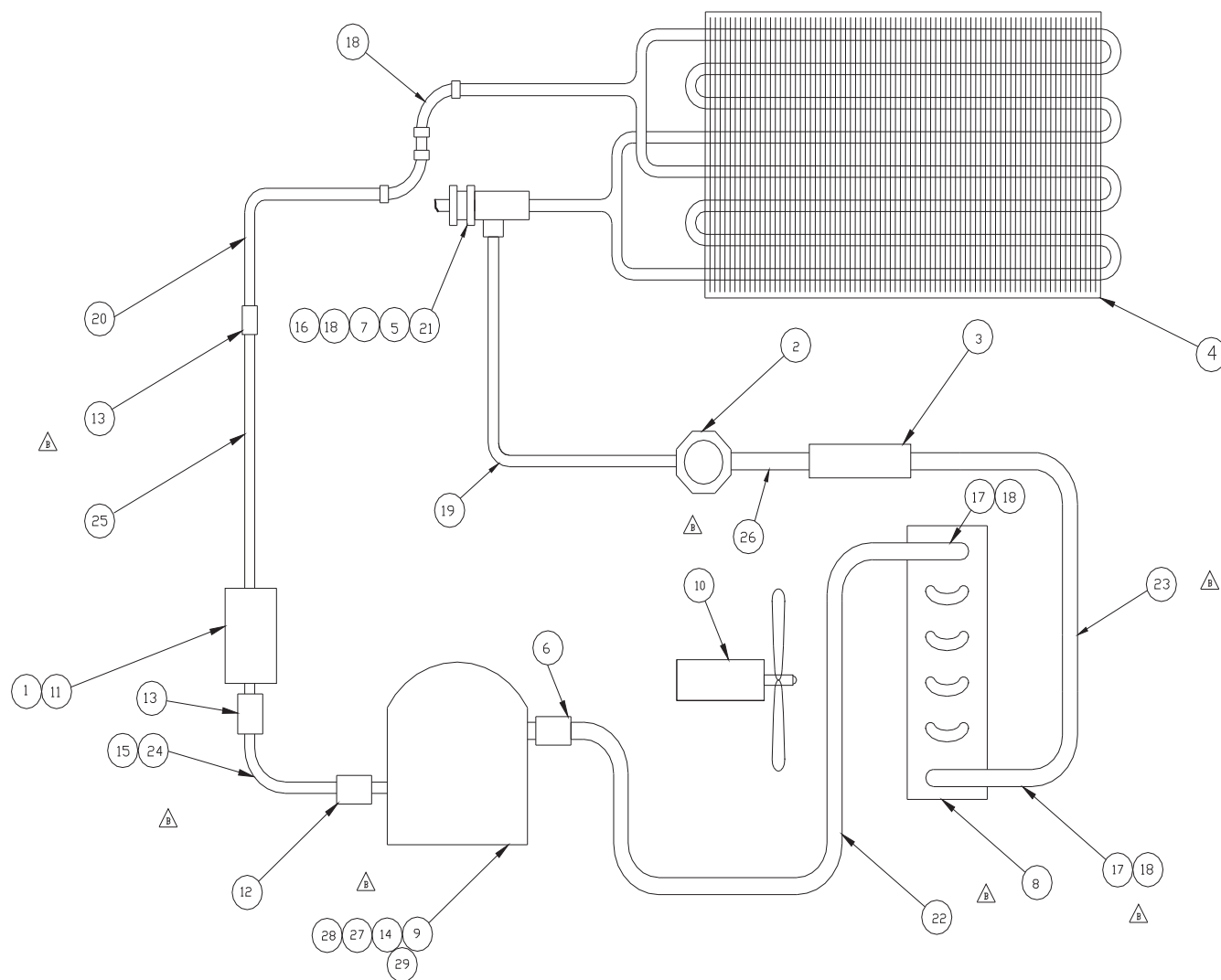


Figure 13: C-25KC Refrigeration Schematic



Callouts are identified in Table 6 on the following page.

Table 6: Callouts from Refrigeration Schematic

Item #	Part Number	Description	Qty.
1	P0840-0120	Refrigerant R134A	A/R
2	A-150	Sight Glass	1
3	P0220-1210	Filter/Dryer	1
4	M1193-9949	Cooling Coil	1
5	P0220-2081	Valve Diap. Refrigerant Brass	1
6	W-1003	Coupling Cop Rlldstop 1/4" C-C	1
7	W-2312	Elbow, 90°, 1/4" X 1/4" CP	1
8	M1164-0100	Condenser Unit	1
9	P0620-0811	Compressor 115 VAC 60 Hz, 1 phase	1
10	P0620-2591	Fan 6" Round Alum. 100°C	1
11	P0220-4600	Vlv Shut Off Refrn	1
12	W-1010	Coupling 3/8" X 5/16" Copper	1
13	W-1009	Coupling Cop Rlldstop 3/8" C-C	2
14	M1164-0640	Base Assembly	1
15	P0740-3201	Tubing, Poleyth, 3/8" ID X 3/8" WAL	3
16	W-2115	Elbow, 90°, 3/8" X 1/4" Br	1
17	W-1706	Bushing Fish 1/4" X 1/8"	2
18	W-2009	Elbow, 90°, 1/4" X 1/4" CP	4
19	M1246-9112	Tube	1
20	M1246-9113	Tube	1
21	M1246-9114	Tube	1
22	M1246-9115	Tube	1
23	M1246-9116	Tube	1
24	M1246-9117	Tube	1
25	M1246-9118	Tube	1
26	M1246-9119	Tube	1
27	S1121-6089	Screw, 1/4-20 X 1/2"	4
28	W1217-3128	Washer, 1/4" Lock Zinc	4
29	M1246-9311	Adapter Base	1

10.1 List of Drawings

Figure	Description	Page
1	Keypad	21
2	Platform Screw Locations	23
3a	Double Girdle Clamp Installation	24
3b	Clamp Fastener	24
4	C-25 and C-25KC Rear Panel	26, 31
5	C-25 and C-25KC Front Panel	27
6	Fuse Holder (detail)	32
7	Belt Removal	33
8	Flexure Attaching Hardware (reverse view)	33
9	C-25 115 VAC Control Schematic	39
10	C-25 230 VAC Control Schematic	44
11	C-25KC 115 VAC Control Schematic	49
12	C-25KC 230 VAC Control Schematic	54
13	C25KC Refrigeration Schematic	59

10.2 List of Tables

Table	Description	Page
1	Clamp Hardware Application Chart	25
2	Service Parts	37
3	Platforms	37
4	Universal Platform Flask Capacity	38
5	Carriers & Test Tube Racks	38
6	Callouts from Refrigeration Schematic	60

THIS PAGE IS INTENTIONALLY BLANK

11 INDEX

A

Accessories · 37
 Alarm Functions · 29
 Ambient Temperature · 13
 Audible Alarm
 Disabling · 29

B

Belt Replacement · 32
 Belt Replacement · 33

C

Carriers · 38
 CAUTION · 7
 Checking Setpoints · 28
 Clamp Hardware · 25
 Cleaning External Surfaces · 31
 Continuous Run · 28
 Control Schematic
 C-25KC 115VAC · 49
 Control Schematics · 39
 Copyright · 7

D

Dedicated Platforms · 37
 Double Girdle Clamps · 24
 Drawings
 Index of · 61

E

Electrical Connections · 25
 Environment · 19

F

Flask Capacity
 Universal Platform · 38
 Flask Clamps
 Installation of · 24
 Front Panel · 27
 Function Indicators · 22
 Fuse
 Replacement · 31
 Fuse Holders · 26

I

Inspection · 17
 Installation
 Platform · 23
 Installing Flask Clamps · 24
 International Offices · 3

K

Keypad
 Features · 21
 Keypad Location · 27

L

LED Display · 21
 Lid Indication · 27
 Lifting the Shaker · 19

M

Maint Indicator
 Disabling · 30
 Manual Conventions · 7

N

NOTE · 7

O

On/Off Switch Location · 27
 Operation · 27
 Overview · 13

P

Platform
 Installation · 23
 Platform Assemblies · 22
 Platforms · 37
 Power Connector · 26
 Power Failure · 30
 Power Kit · 17
 Preventive Maintenance · 31

R

Rear Panel · 26
Refrigeration Schematic
 C-25KC · 59
Relative Humidity · 19
Replacement Parts · 37

S

Service Parts · 37
Setting the Timer · 28
Specifications
 C-25 · 14
 C-25KC · 15
Starting the Unit · 27
Status Indicators · 22

T

Table of Contents · 11
Tables
 Index of · 61
Temperature Control
 Disabling · 29

Temperature Setpoint · 29
Test Tube Racks · 38
Timed Functions · 28
Timer
 Setting the · 28
Total Running Time · 30
Troubleshooting · 35

U

Universal Platform · 37
Unlimited Run · 28
Unpacking · 17
User Interface Keys · 21

V

Visual Alarm
 Disabling · 29

W

WARNING · 7
Warranty · 9



Artisan Technology Group is your source for quality new and certified-used/pre-owned equipment

- FAST SHIPPING AND DELIVERY
- TENS OF THOUSANDS OF IN-STOCK ITEMS
- EQUIPMENT DEMOS
- HUNDREDS OF MANUFACTURERS SUPPORTED
- LEASING/MONTHLY RENTALS
- ISTAR CERTIFIED SECURE ASSET SOLUTIONS

SERVICE CENTER REPAIRS

Experienced engineers and technicians on staff at our full-service, in-house repair center

InstraView[™] REMOTE INSPECTION

Remotely inspect equipment before purchasing with our interactive website at www.instraview.com ↗

WE BUY USED EQUIPMENT

Sell your excess, underutilized, and idle used equipment. We also offer credit for buy-backs and trade-ins www.artisantg.com/WeBuyEquipment ↗

LOOKING FOR MORE INFORMATION?

Visit us on the web at www.artisantg.com ↗ for more information on price quotations, drivers, technical specifications, manuals, and documentation

Contact us: (888) 88-SOURCE | sales@artisanng.com | www.artisantg.com